

DEVICE PERFORMANCE SPECIFICATION

Revision 1.0 MTD/PS-0938

January 30, 2006

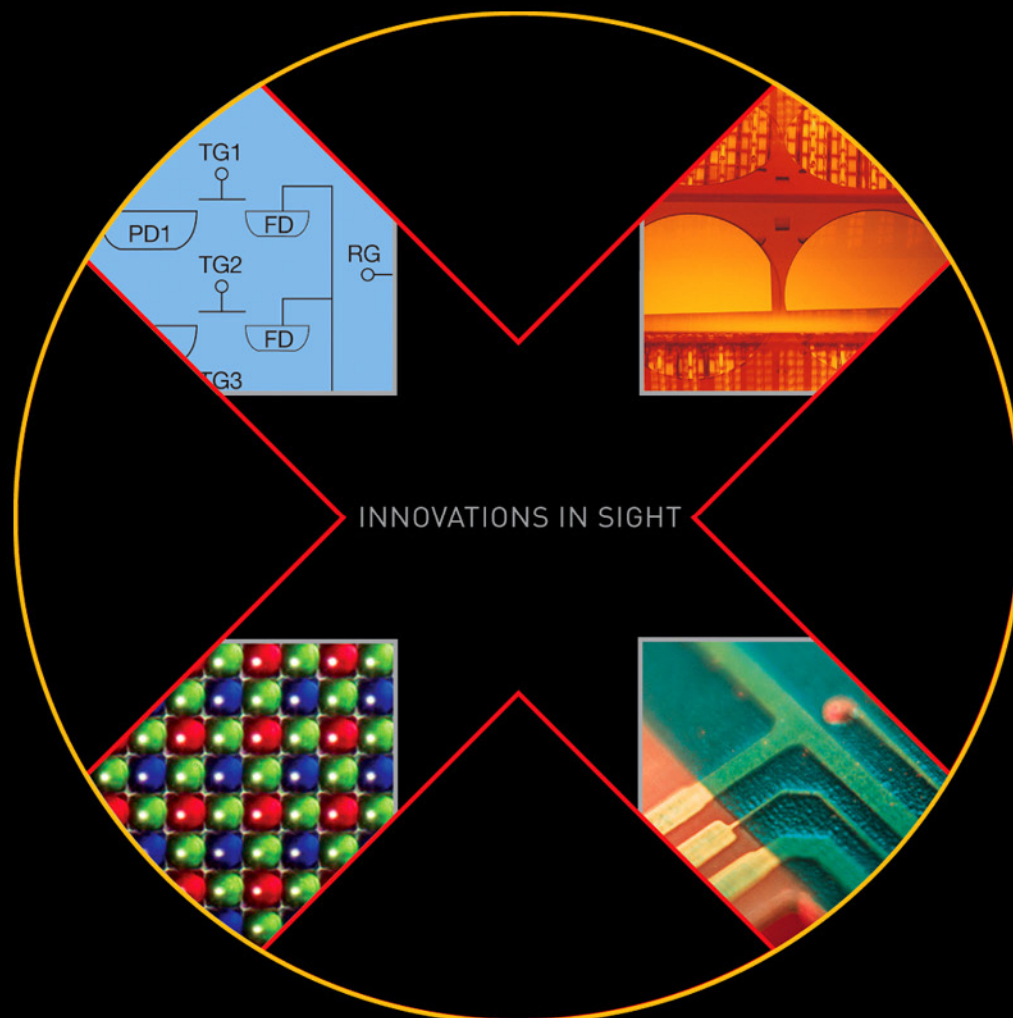

KODAK KAI-11002 IMAGE SENSOR

4008(H) X 2672(V) INTERLINE CCD IMAGE SENSOR

Kodak
Image Sensor Solutions

TABLE OF CONTENTS

Summary Specification	5
Device Description	6
Architecture	6
Pixel	7
Vertical to Horizontal Transfer	8
Horizontal Register to Floating Diffusion	9
Horizontal Register Split	10
Single Output Operation	10
Dual Output Operation	10
Output	11
Pin Description and Physical Orientation	12
Performance	13
Power - Estimated	13
Frame Rates - Continuous Mode	13
Imaging Performance	14
Imaging Performance Operational Conditions	14
Imaging Performance Specifications	14
Defect Definitions	16
Quantum Efficiency	17
Angular Quantum Efficiency	19
Test Definitions	20
Test Regions of Interest	20
OverClocking	20
Tests	21
Operation	22
Maximum Ratings	22
Maximum Voltage Ratings Between Pins	22
DC Bias Operating Conditions	22
AC Operating Conditions	23
Clock Levels	23
Clock Line Capacitances	23
Timing Requirements	23
Main Timing - Continuous Mode	24
Frame Timing - Continuous Mode	25
Frame Timing without Binning	25
Frame Timing for Vertical Binning by 2	25
Frame Timing Edge Alignment	26
Line Timing - Continuous Mode	27
Line Timing Single Output	27
Line Timing Dual Output - Left Output	27
Line Timing Dual Output - Right Output	28
Line Timing Vertical Binning by 2	28
Line Timing Detail	29
Line Timing Binning by 2 Detail	29
Line Timing Edge Alignment	30
Pixel Timing - Continuous Mode	31

Pixel Timing Detail.....	31
Fast Line Dump Timing.....	32
Electronic Shutter	33
Electronic Shutter Line Timing	33
Electronic Shutter – Integration Time Definition	33
Electronic Shutter Description	34
Storage and Handling	35
Mechanical Drawings.....	36
Package	36
Die to Package Alignment.....	37
Glass	38
Glass Transmission.....	39
Quality Assurance and Reliability.....	40
Ordering Information	41
Revision Changes.....	42

TABLE OF FIGURES

Figure 1: Sensor Architecture	6
Figure 2: Pixel Architecture.....	7
Figure 3: Vertical to Horizontal Transfer Architecture.....	8
Figure 4: Horizontal Register to Floating Diffusion Architecture	9
Figure 5: Horizontal Register	10
Figure 6: Output Architecture.....	11
Figure 7: Pin Description	12
Figure 8: Power	13
Figure 9: Frame Rates	13
Figure 10: Color with Microlens Quantum Efficiency Using AR Glass	17
Figure 11: Color without Microlens Quantum Efficiency Using AR Glass	17
Figure 12: Monochrome with Microlens Quantum Efficiency.....	18
Figure 13: Monochrome without Microlens Quantum Efficiency.....	18
Figure 14: Monochrome with Lenslets Angular Quantum Efficiency	19
Figure 15: Color with Lenslets Angular Quantum Efficiency.....	19
Figure 16: Overclock Regions of Interest.....	20
Figure 17: Main Timing - Continuous Mode.....	24
Figure 18: Framing Timing without Binning	25
Figure 19: Frame Timing for Vertical Binning by 2.....	25
Figure 20: Frame Timing Edge Alignment	26
Figure 21: Line Timing Single Output.....	27
Figure 22: Line Timing Dual Output – Left Output.....	27
Figure 23: Line Timing Dual Output – Right Output	28
Figure 24: Line Timing Vertical Binning by 2	28
Figure 25: Line Timing Detail	29
Figure 26: Line Timing by 2 Detail.....	29
Figure 27: Line Timing Edge Alignment.....	30
Figure 28: Pixel Timing	31
Figure 29: Pixel Timing Detail	31
Figure 30: Fast Line Dump Timing.....	32
Figure 31: Electronic Shutter Line Timing.....	33
Figure 32: Integration Time Definition	33
Figure 33: Package Drawing	36
Figure 34: Die to Package Alignment.....	37
Figure 35: Glass Drawing	38
Figure 36: Glass Transmission.....	39

SUMMARY SPECIFICATION

KODAK KAI-11002 IMAGE SENSOR

4008 (H) X 2672 (V) INTERLINE TRANSFER PROGRESSIVE SCAN CCD

DESCRIPTION

The Kodak KAI-11002 Image Sensor is a high-performance 11-million pixel sensor designed for professional digital still camera applications. The 9.0 μm square pixels with microlenses provide high sensitivity and the large full well capacity results in high dynamic range. The two high-speed outputs and binning capabilities allow for 1-3 frames per second (fps) video rate for the progressively scanned images. The vertical overflow drain structure provides antiblooming protection and enables electronic shuttering for precise exposure control. Other features include low dark current, negligible lag and low smear.

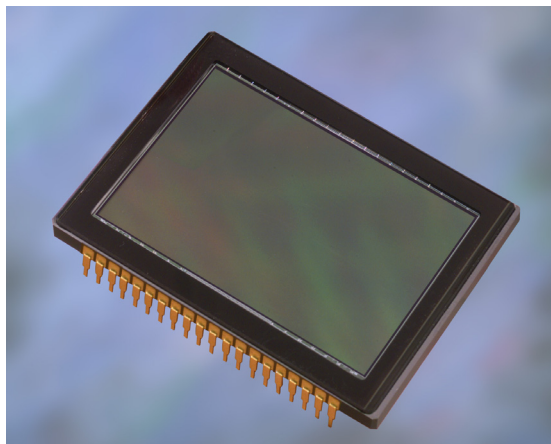

FEATURES

- High resolution
- High sensitivity
- High dynamic range
- Low noise architecture
- High frame rate
- Binning capability for higher frame rate
- Electronic shutter

APPLICATIONS

- Industrial inspection
- Aerial Photography

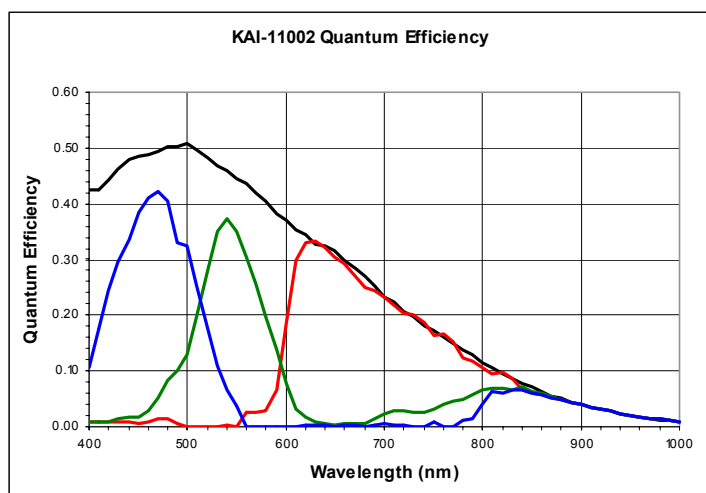

Parameter	Value
Architecture	Interline CCD; Progressive Scan
Total Number of Pixels	4072 (H) x 2720 (V) = 11.1M
Number of Effective Pixels	4032 (H) x 2688 (V) = 10.8M
Number of Active Pixels	4008 (H) x 2672 (V) = 10.7M
Number of Outputs	1 or 2
Pixel Size	9.0 μm (H) x 9.0 μm (V)
Imager Size	43.3mm (diagonal)
Chip Size	37.25mm (H) x 25.70mm (V)
Aspect Ratio	3:2
Saturation Signal	60,000 electrons
Quantum Efficiency (KAI-11002-ABA)	50%
Quantum Efficiency (KAI-11002-CBA) RGB	34%, 37%, 42%
Output Sensitivity	13 $\mu\text{V}/\text{e}$
Total Noise	30 electrons
Dark Current	< 50 mV/s
Dark Current Doubling Temperature	7 $^{\circ}\text{C}$
Dynamic Range	66 dB
Charge Transfer Efficiency	> 0.99999
Blooming Suppression	> 1000X
Smear	< -80 dB
Image Lag	< 10 electrons
Maximum Data Rate	28 MHz
Package	40-pin, CerDIP, 0.070" pin spacing
Cover Glass	AR Coated

All parameters above are specified at T = 40 $^{\circ}\text{C}$

DEVICE DESCRIPTION

ARCHITECTURE

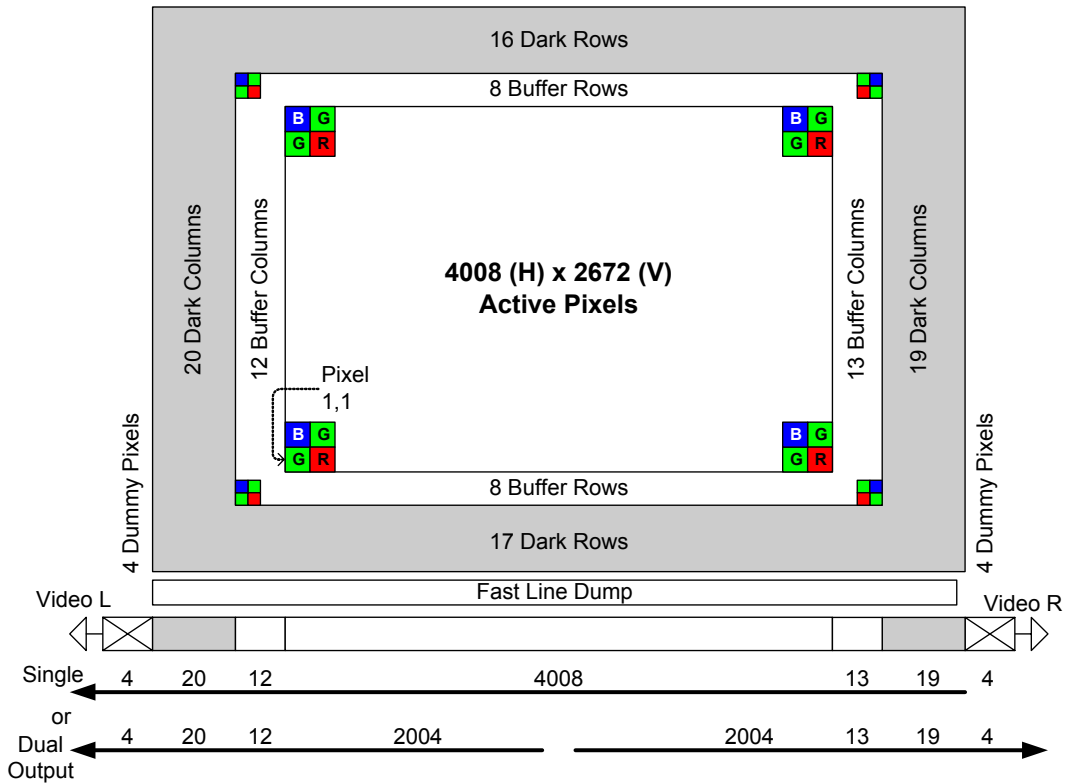

Figure 1: Sensor Architecture

There are 17 light shielded rows followed 2688 photoactive rows and finally 16 more light shielded rows. The first 8 and the last 8 photoactive rows are buffer rows giving a total of 2672 lines of image data.

In the single output mode all pixels are clocked out of the Video L output in the lower left corner of the sensor. The first 4 empty pixels of each line do not receive charge from the vertical shift register. The next 20 pixels receive charge from the left light shielded edge followed by 4033 photosensitive pixels and finally 19 more light shielded pixels from the right edge of the sensor. The first 12 and last 13 photosensitive pixels are buffer pixels giving a total of 4008 pixels of image data.

In the dual output mode the clocking of the right half of the horizontal CCD is reversed. The left half of the image is clocked out Video L and the right half of the image is

clocked out Video R. For the Video L each row consists of 4 empty pixels followed by 20 light shielded pixels followed by 2016 photosensitive pixels. For the Video R each row consists of 4 empty pixels followed by 19 light shielded pixels followed by 2017 photosensitive pixels. When reconstructing the image, data from Video R will have to be reversed in a line buffer and appended to the Video L data.

The dark rows are not entirely dark and so should not be used for a dark reference level. Use the dark columns on the left or right side of the image sensor as a dark reference.

Of the dark columns, the first and last dark columns should not be used for determining the zero signal level. Some light does leak into the first and last dark columns.

PIXEL

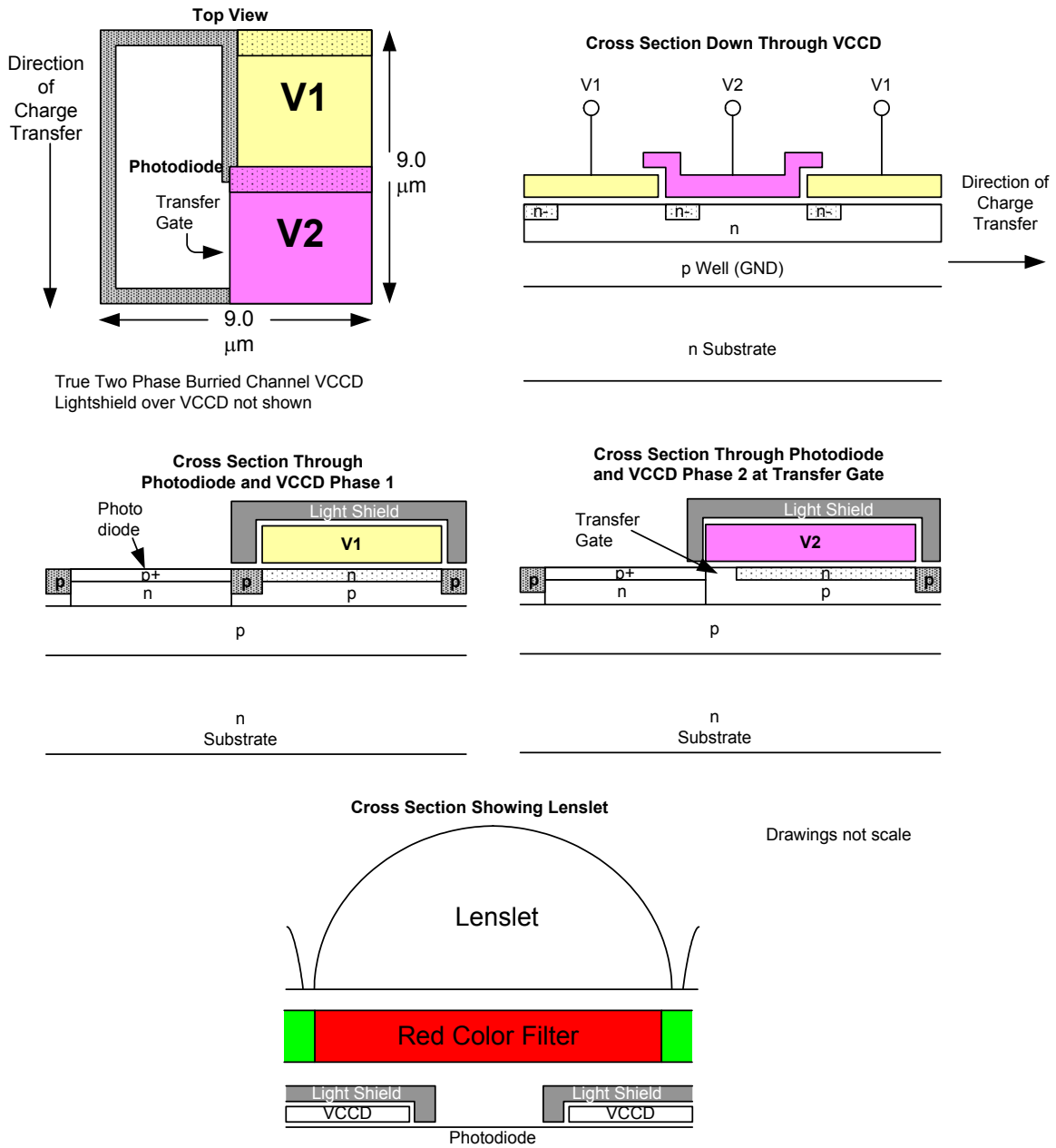

Figure 2: Pixel Architecture

An electronic representation of an image is formed when incident photons falling on the sensor plane create electron-hole pairs within the individual silicon photodiodes. These photoelectrons are collected locally by the formation of potential wells at each photosite. Below photodiode saturation, the number of

photoelectrons collected at each pixel is linearly dependant upon light level and exposure time and non-linearly dependant on wavelength. When the photodiodes charge capacity is reached, excess electrons are discharged into the substrate to prevent blooming.

VERTICAL TO HORIZONTAL TRANSFER

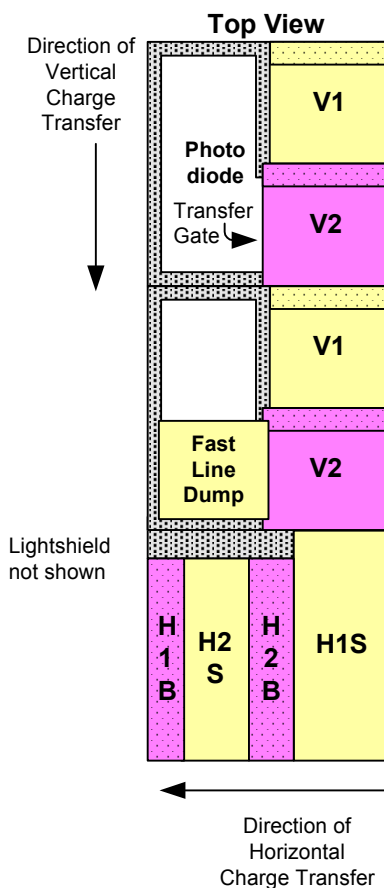

Figure 3: Vertical to Horizontal Transfer Architecture

When the V1 and V2 timing inputs are pulsed, charge in every pixel of the VCCD is shifted one row towards the HCCD. The last row next to the HCCD is shifted into the HCCD. When the VCCD is shifted, the timing signals to the HCCD must be stopped. H1 must be stopped in the high state and H2 must be stopped in the low state. The HCCD clocking may begin THD μ s after the falling edge of the V1 and V2 pulse.

Charge is transferred from the last vertical CCD phase into the H1S horizontal CCD phase. Refer to Figure 25 for an example of timing that accomplishes the vertical to horizontal transfer of charge.

If the fast line dump is held at the high level (FDH) during a vertical to horizontal transfer, then the entire line is removed and not transferred into the horizontal register.

HORIZONTAL REGISTER TO FLOATING DIFFUSION

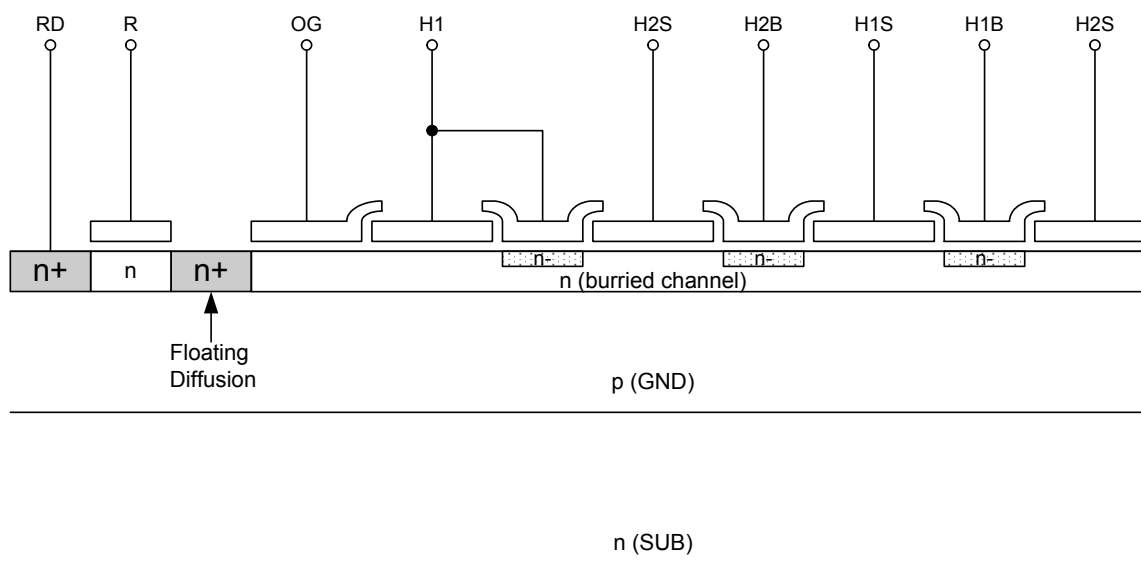

Figure 4: Horizontal Register to Floating Diffusion Architecture

The HCCD has a total of 4080 pixels. The 4072 vertical shift registers (columns) are shifted into the center 4072 pixels of the HCCD. There are 4 pixels at both ends of the HCCD, which receive no charge from a vertical shift register. The first 4 clock cycles of the HCCD will be empty pixels (containing no electrons). The next 20 clock cycles will contain only electrons generated by dark current in the VCCD and photodiodes. The next 4033 clock cycles will contain photo-electrons (image data). Finally, the last 19 clock cycles will contain only electrons generated by dark current in the VCCD and photodiodes. Of the 20 dark columns at the start of the line and the 19 dark columns at the end of the line, the first and last dark columns should not be used for determining the zero signal level. Some light does leak into the first and last dark columns. Only use the center 18 columns of the 20 column dark reference at the start

of the line. Only use the center 17 columns of the 19 column dark reference at the end of the line.

When the HCCD is shifting valid image data, the timing inputs to the electronic shutter (SUB), VCCD (V1, V2), and fast line dump (FD) should not be pulsed. This prevents unwanted noise from being introduced. The HCCD is a type of charge coupled device known as a pseudo-two phase CCD. This type of CCD has the ability to shift charge in two directions. This allows the entire image to be shifted out to the video L output, or to the video R output (left/right image reversal). The HCCD is split into two equal halves of 2040 pixels each. When operating the sensor in single output mode the two halves of the HCCD are shifted in the same direction. When operating the sensor in dual output mode the two halves of the HCCD are shifted in opposite directions. The direction of charge transfer in each half is controlled by the H1BL, H2BL, H1BR, and H2BR timing inputs.

HORIZONTAL REGISTER SPLIT

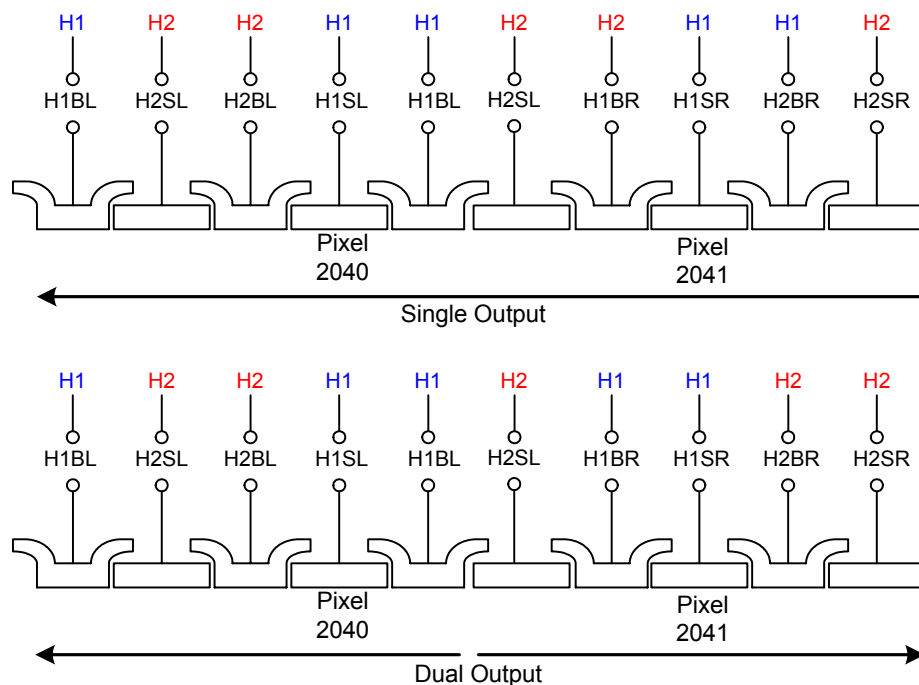

Figure 5: Horizontal Register

Single Output Operation

When operating the sensor in single output mode all pixels of the image sensor will be shifted out the Video L output (pin 2). To conserve power and lower heat generation the output amplifier for Video R may be turned off by connecting VDDR (pin 18) and VOUTR (pin 19) to GND (zero volts).

The H1 timing from the timing diagrams should be applied to H1SL, H1BL, H1SR, H2BR, and the H2 timing should be applied to H2SL, H2BL, H2SR, and H1BR. In other words, the clock driver generating the H1 timing should be connected to pins 8, 9, 13, and 11. The clock driver generating the H2 timing should be connected to pins 7, 10, 14, and 12. The horizontal CCD should be clocked for 4 empty pixels plus 20 light shielded pixels plus 4032 photoactive pixels plus 20 light shielded pixels for a total of 4076 pixels. H1BINL and H1BINR use the H1 timing, but should be generated from a separate clock driver for optimal performance.

Dual Output Operation

In dual output mode the connections to the H1BR and H2BR pins are swapped from the single output mode to change the direction of charge transfer of the right side horizontal shift register. In dual output mode both VDDL and VDDR (pins 3, 18) should be connected to 15 V. The H1 timing from the timing diagrams should be applied to H1SL, H1BL, H1SR, H1BR, and the H2 timing should be applied to H2SL, H2BL, H2SR, and H2BR. The clock driver generating the H1 timing should be connected to pins 8, 9, 13, and 12. The clock driver generating the H2 timing should be connected to pins 7, 10, 14, and 11. The horizontal CCD should be clocked for 4 empty pixels plus 20 light shielded pixels plus 2016 photoactive pixels for a total of 2040 pixels. If the camera is to have the option of dual or single output mode, the clock driver signals sent to H1BR and H2BR may be swapped by using a relay. Another alternative is to have two extra clock drivers for H1BR and H2BR and invert the signals in the timing logic generator. If two extra clock drivers are used, care must be taken to ensure the rising and falling edges of the H1BR and H2BR clocks occur at the same time (within 3ns) as the other HCCD clocks.

OUTPUT

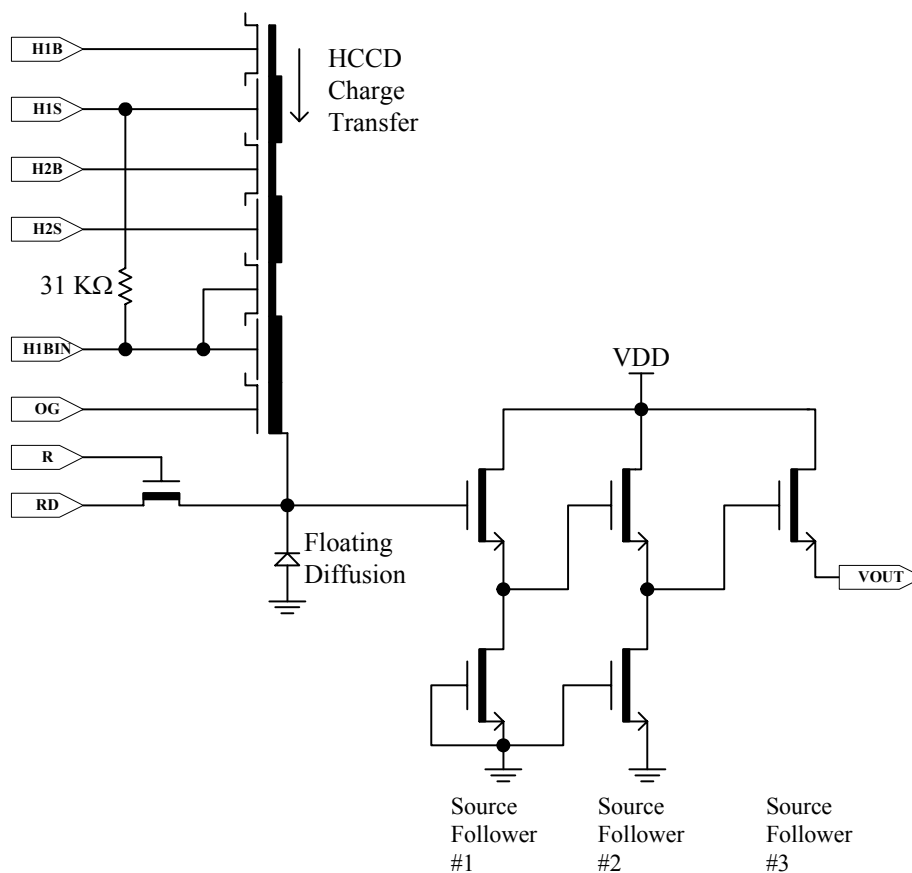
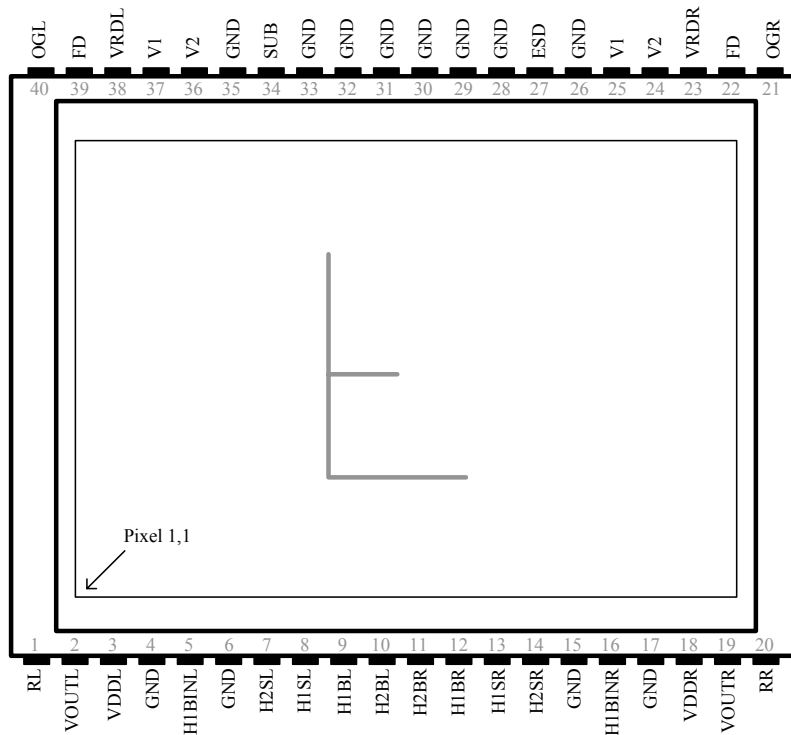

Figure 6: Output Architecture

Charge packets contained in the horizontal register are dumped pixel by pixel onto the floating diffusion (fd) output node whose potential varies linearly with the quantity of charge in each packet. The amount of potential charge is determined by the expression $\Delta V_{fd} = \Delta Q / C_{fd}$. A three-stage source-follower amplifier is used to buffer this signal voltage off chip with slightly

less than unity gain. The translation from the charge domain to the voltage domain is quantified by the output sensitivity or charge to voltage conversion in terms of microvolts per electron ($\mu V/e^-$). After the signal has been sampled off chip, the reset clock (R) removes the charge from the floating diffusion and resets its potential to the reset drain voltage (RD).

PIN DESCRIPTION AND PHYSICAL ORIENTATION



Pin	Name	Description
1	RL	Reset Gate, Left
2	VOUTL	Video Output, Left
3	VDDL	Vdd, Left
4	GND	Ground
5	H1BINL	H1 Last Phase, Left
6	GND	Ground
7	H2SL	H2 Storage, Left
8	H1SL	H1 Storage, Left
9	H1BL	H1 Barrier, Left
10	H2BL	H2 Barrier, Left
11	H2BR	H2 Barrier, Right
12	H1BR	H1 Barrier, Right
13	H1SR	H1 Storage, Right
14	H2SR	H2 Storage, Right
15	GND	Ground
16	H1BINR	H1 Last Phase, Right
17	GND	Ground
18	VDDR	Vdd, Right
19	VOUTR	Video Output, Right
20	RR	Reset Gate, Right

Pin	Name	Description
40	OGL	Output Gate, Left
39	FD	Fast Line Dump Gate
38	RDL	Reset Drain, Left
37	V1	Vertical Clock, Phase 1
36	V2	Vertical Clock, Phase 2
35	GND	Ground
34	SUB	Substrate
33	GND	Ground
32	GND	Ground
31	GND	Ground
30	GND	Ground
29	GND	Ground
28	GND	Ground
27	ESD	ESD Protection
26	GND	Ground
25	V1	Vertical Clock, Phase 1
24	V2	Vertical Clock, Phase 2
23	RDR	Reset Drain, Right
22	FD	Fast Line Dump Gate
21	OGR	Output Gate, Right

The pins are on a 0.070" spacing

Figure 7: Pin Description

PERFORMANCE

POWER - ESTIMATED

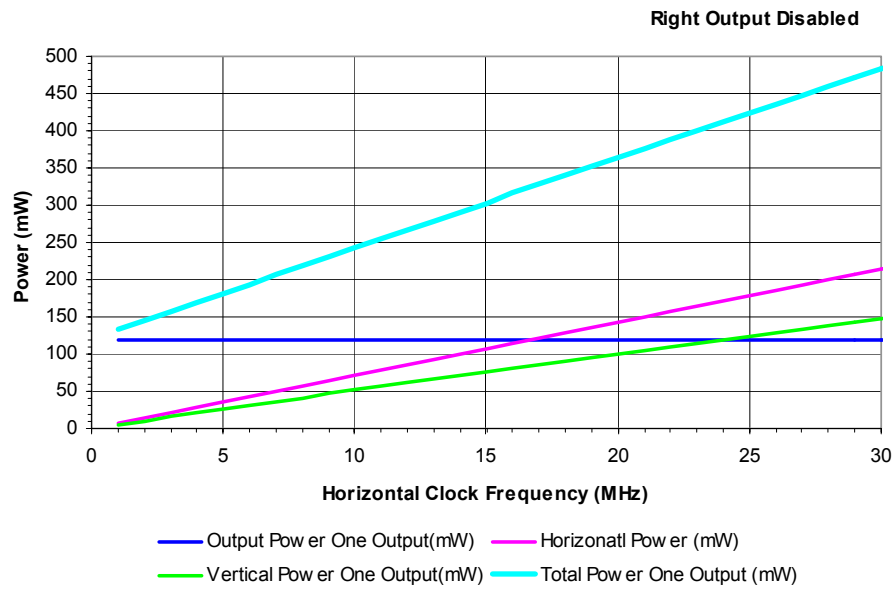

Figure 8: Power

FRAME RATES – CONTINUOUS MODE

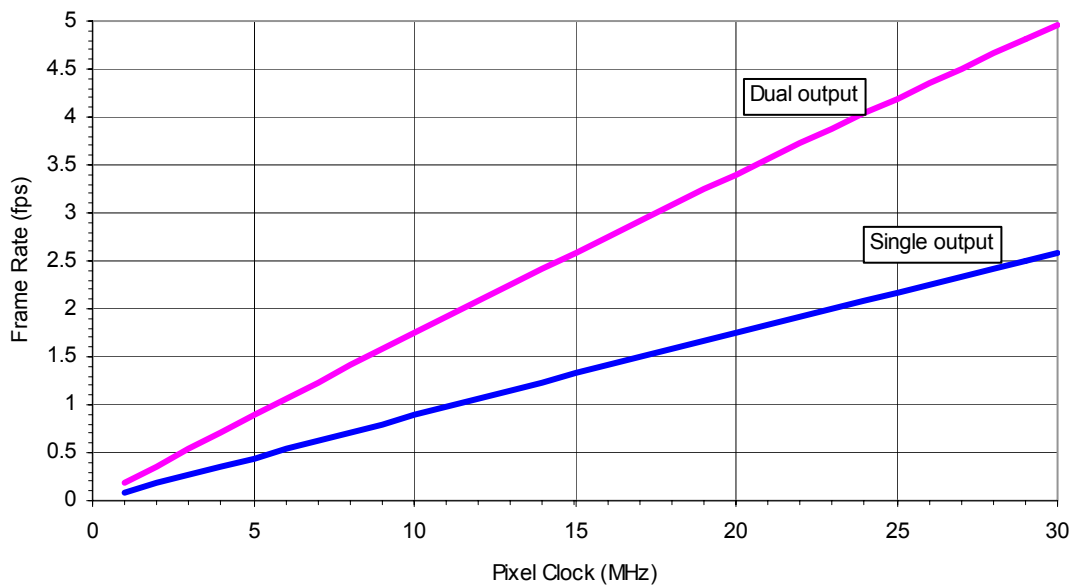

Figure 9: Frame Rates

IMAGING PERFORMANCE

Imaging Performance Operational Conditions

Unless otherwise noted, the Imaging Performance Specifications are measured using the following conditions.

Description	Condition	Notes
Frame Time	1732 msec	1
Horizontal Clock Frequency	10 MHz	
Light Source	Continuous red, green and blue illumination centered at 450, 530 and 650 nm	2,3
Operation	Nominal operating voltages and timing	

Notes:

- Electronic shutter is not used. Integration time equals frame time.
- LEDs used: Blue: Nichia NLPB500, Green: Nichia NSPG500S and Red: HP HLMP-8115.
- For monochrome sensor, only green LED used.

Imaging Performance Specifications

KAI-11002-ABA Monochrome with Microlens and KAI-11002-CBA Color with Microlens

Description	Symbol	Min.	Nom.	Max.	Units	Sampling Plan	Temperature Tested At (°C)	Notes	Test
Maximum Photoresponse Nonlinearity	NL	n/a	2		%	Design		2, 3	
Maximum Gain Difference Between Outputs	ΔG	n/a	10		%	Design		2, 3	
Max. Signal Error due to Nonlinearity Dif.	ΔNL	n/a	1		%	Design		2, 3	
Horizontal CCD Charge Capacity	HNe		139		ke ⁻	Design			
Vertical CCD Charge Capacity	VNe	90	91		ke ⁻	Die			
Photodiode Charge Capacity	PNe	58	60		ke ⁻	Die			
Horizontal CCD Charge Transfer Efficiency	HCTE	0.99999		n/a		Design			
Vertical CCD Charge Transfer Efficiency	VCTE	0.99999		n/a		Design			
Photodiode Dark Current	l _{pd}	n/a		800	e/p/s	Die	27, 40		
Photodiode Dark Current	l _{pd}	n/a		0.15	nA/cm ²	Die	27, 40		
Vertical CCD Dark Current	l _{vd}	n/a		3800	e/p/s	Die	27, 40		
Vertical CCD Dark Current	l _{vd}	n/a		0.5	nA/cm ²	Die	27, 40		
Image Lag	Lag	n/a	<10	50	e ⁻	Design			
Antiblooming Factor	X _{ab}	100	300	n/a		Design			
Vertical Smear	Smr	n/a	-85	-75	dB	Design			
Total Noise	n _{e-T}		30		e ⁻ rms	Design		4	
Dynamic Range	DR		66		dB	Design		5	
Output Amplifier DC Offset	V _{odc}	4	9	14	V	Die			
Output Amplifier Bandwidth	F _{-3db}		106		MHz	Die		6	
Output Amplifier Impedance	R _{OUT}	100	150	200	Ohms	Die			
Output Amplifier Sensitivity	$\Delta V/\Delta N$		13		$\mu V/e^-$	Design			

KAI-11002-ABA Monochrome with Microlens

Description	Symbol	Min.	Nom.	Max.	Units	Sampling Plan	Temperature Tested At (°C)	Notes	Test
Peak Quantum Efficiency	QE _{max}	45	50	n/a	%	Design			
Peak Quantum Efficiency Wavelength	λQE	n/a	500	n/a	nm				

KAI-11002-CBA Color with Microlens

Description	Symbol	Min.	Nom.	Max.	Units	Sampling Plan	Temperature Tested At (°C)	Notes	Test
Peak Quantum Efficiency Red Green Blue	QE _{max}		34 37 42	n/a n/a n/a	%	Design			
Peak Quantum Efficiency Wavelength Red Green Blue	λQE		630 550 470	n/a n/a n/a	nm	Design			

n/a: not applicable

Notes:

1. Per color.
2. Value is over the range of 10% to 90% of photodiode saturation.
3. Value is for the sensor operated without binning
4. Includes system electronics noise, dark pattern noise and dark current shot noise at 30 MHz.
5. Uses $20\text{LOG}(PNe/n_{e-T})$
6. Last stage only, Cload=10pF. Then $f_{-3db} = (1 / (2\pi * R_{out} * C_{load}))$

Defect Definitions

Description	Definition	Class X Monochrome with microlens only	Class 0 Monochrome with microlens only	Class 1	Class 2 Color Only	Class 2 Monochrome Only	Notes	Test
Major dark field defective pixel	Defect >= 239 mV	100	100	100	200	200	1,2	1
Major bright field defective pixel	Defect >= 15 %						1,2	2
Minor dark field defective pixel	Defect >= 123 mV	1000	1000	1000	2000	2000	1,2	1
Cluster defect	A group of 2 to "N" contiguous major defective pixels, but no more than "W" adjacent defects horizontally	0	1 N=10 W=3	20 N=10 W=3	20 N=10 W=3	20 N=12 W=5	1,2	
Column defect	A group of more than 10 contiguous major defective pixels along a single column	0	0	0	10	2	1,2	

Notes:

1. There will be at least two non-defective pixels separating any two major defective pixels.
2. Tested at 27°C and 40°C.

Class X sensors are offered strictly "as available". Kodak cannot guarantee delivery dates. Please call for availability.

Defect Map

The defect map supplied with each sensor is based upon testing at an ambient (27°C) temperature. Minor point defects are not included in the defect map. All defective pixels are reference to pixel 1,1 in the defect maps.

Quantum Efficiency

Color with Microlens Quantum Efficiency

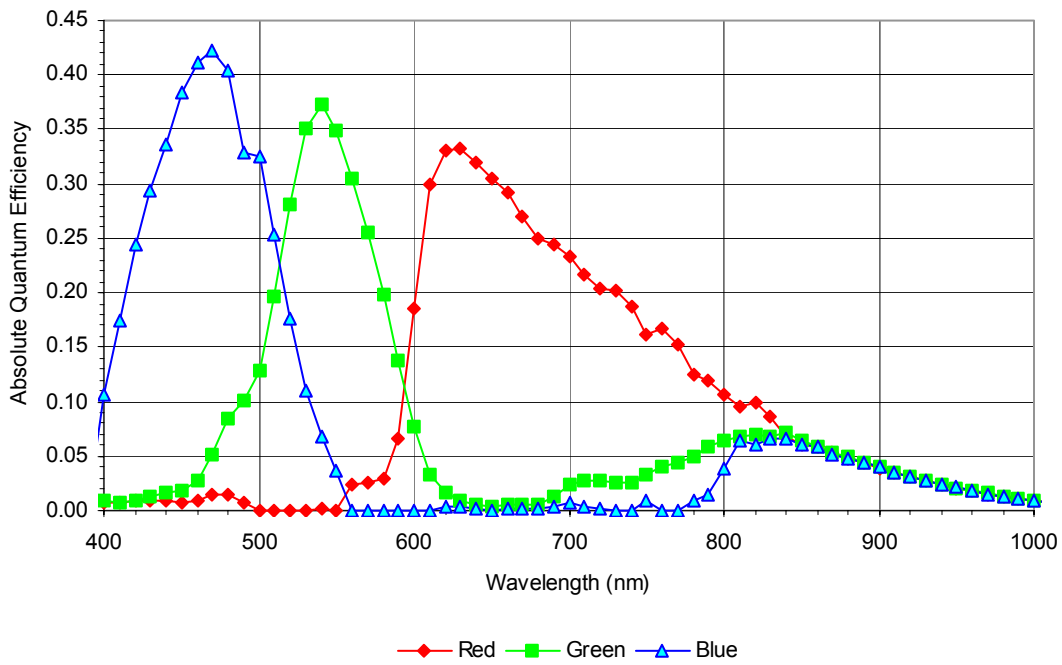

Figure 10: Color with Microlens Quantum Efficiency Using AR Glass

Color without Microlens Quantum Efficiency

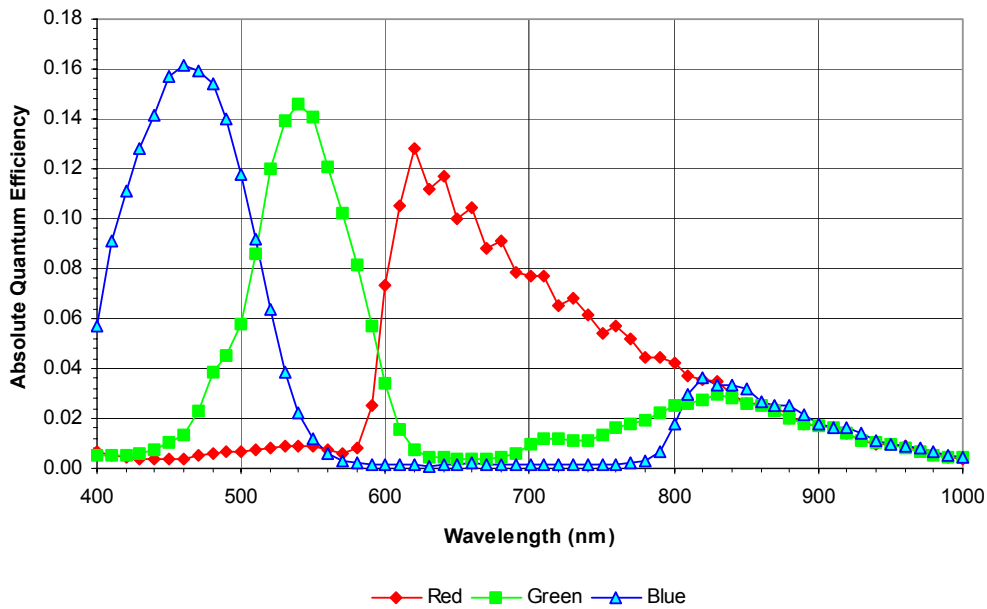

Figure 11: Color without Microlens Quantum Efficiency Using AR Glass

Monochrome with Microlens Quantum Efficiency

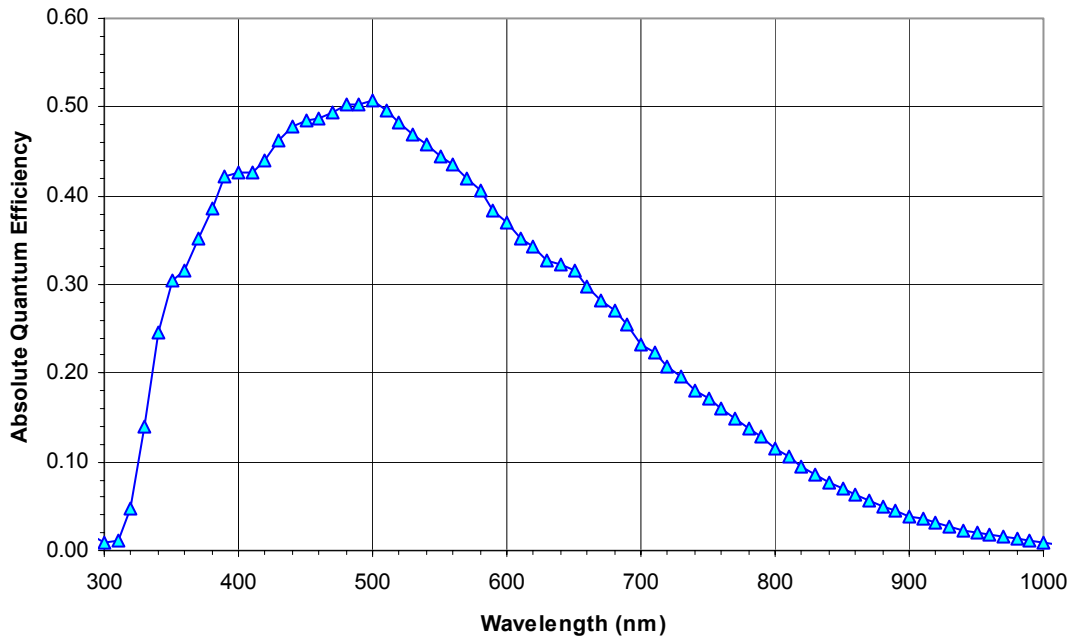

Figure 12: Monochrome with Microlens Quantum Efficiency

Monochrome without Microlens Quantum Efficiency

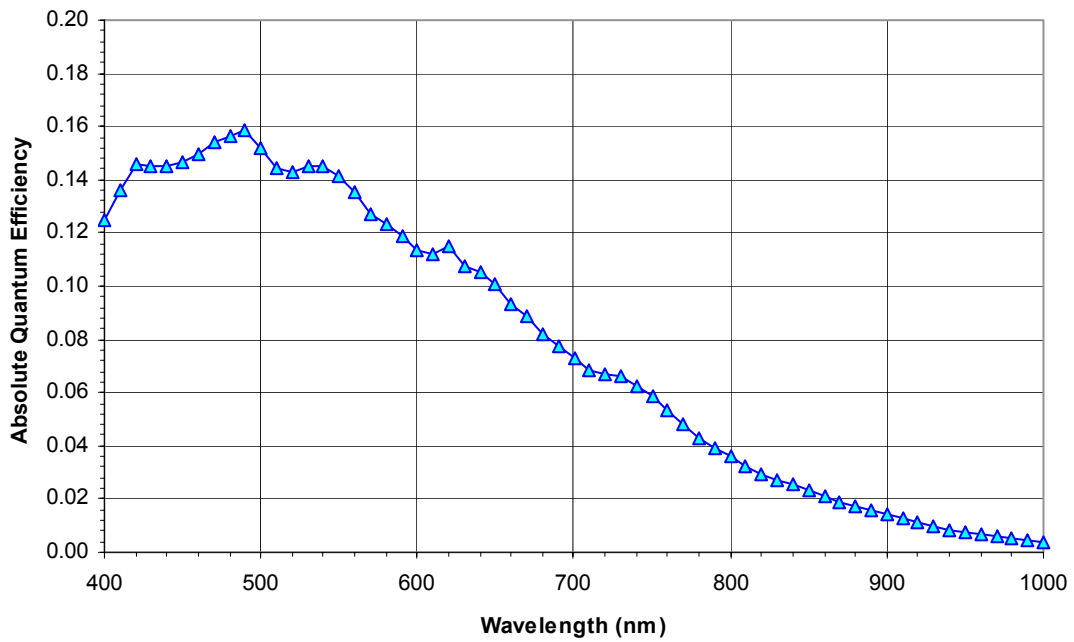

Figure 13: Monochrome without Microlens Quantum Efficiency

Angular Quantum Efficiency

For the curves marked "Horizontal", the incident light angle is varied in a plane parallel to the HCCD.
For the curves marked "Vertical", the incident light angle is varied in a plane parallel to the VCCD.

Monochrome with Lenslets

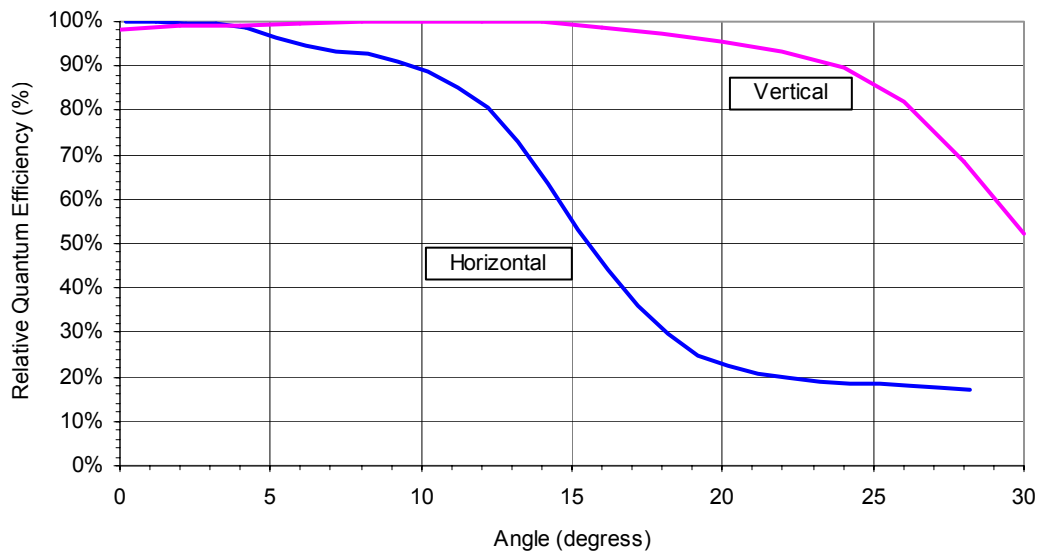

Figure 14: Monochrome with Lenslets Angular Quantum Efficiency

Color with Lenslets

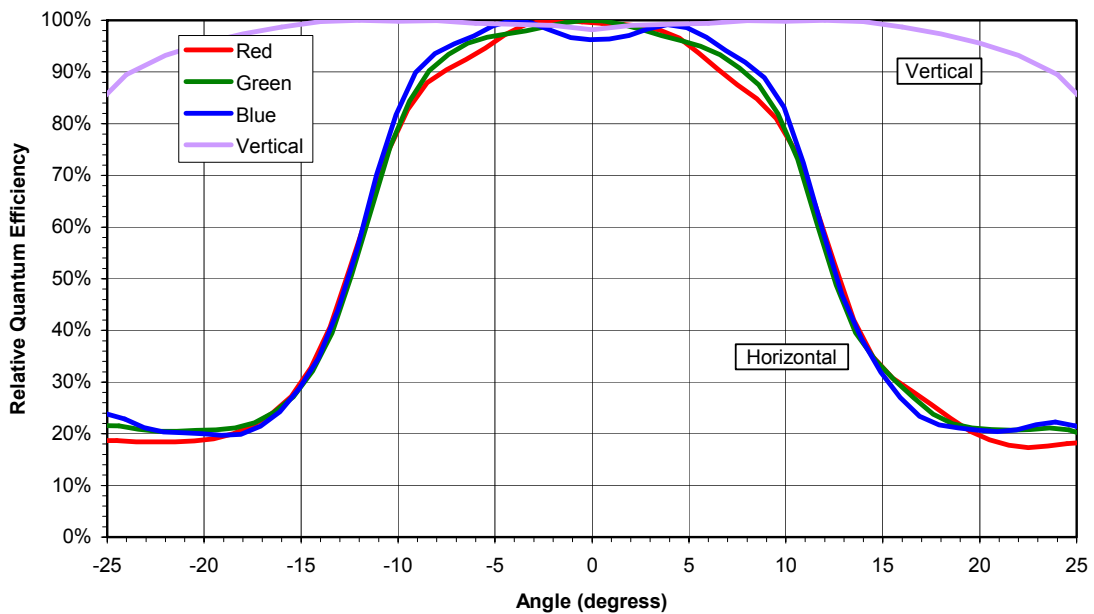

Figure 15: Color with Lenslets Angular Quantum Efficiency

TEST DEFINITIONS

TEST REGIONS OF INTEREST

Active Area ROI: Pixel 1, 1 to Pixel 4008,2672

Center 100 by 100 ROI: Pixel 1954,1336 to Pixel 2053,1435

Only the active pixels are used for performance and defect tests.

OVERCLOCKING

The test system timing is configured such that the sensor is overclocked in both the vertical and horizontal directions. See Figure 16 for a pictorial representation of the regions.

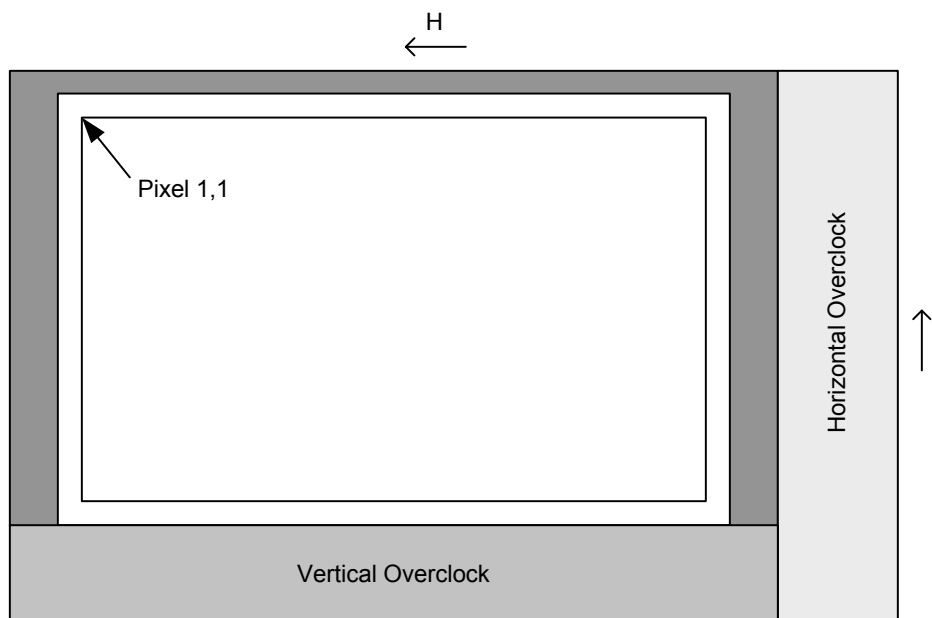

Figure 16: Overclock Regions of Interest

TESTS

1. Dark field defect test

This test is performed under dark field conditions. The sensor is partitioned into 384 sub regions of interest, each of which is 167 by 167 pixels in size. In each region of interest, the median value of all pixels is found. For each region of interest, a pixel is marked defective if it is greater than or equal to the median value of that region of interest plus the defect threshold specified in the "Defect Definitions" section.

2. Bright field defect test

This test is performed with the imager illuminated to a level such that the output is at approximately 40,000 electrons. Prior to this test being performed the substrate voltage has been set such that the charge capacity of the sensor is 60,000 electrons. The average signal level of all active pixels is found. The bright and dark thresholds are set as:

Dark defect threshold = Active Area Signal * threshold

Bright defect threshold = Active Area Signal * threshold

The sensor is then partitioned into 384 sub regions of interest, each of which is 167 by 167 pixels in size. In each region of interest, the average value of all pixels is found. For each region of interest, a pixel is marked defective if it is greater than or equal to the median value of that region of interest plus the bright threshold specified or if it is less than or equal to the median value of that region of interest minus the dark threshold specified.

Example for major bright field defective pixels:

- Average value of all active pixels is found to be 520 mV (40,000 electrons).
- Dark defect threshold: $520\text{mV} * 15\% = 78\text{ mV}$
- Bright defect threshold: $520\text{mV} * 15\% = 78\text{ mV}$
- Region of interest #1 selected. This region of interest is pixels 1,1 to pixels 167,167.
 - Median of this region of interest is found to be 520 mV.
 - Any pixel in this region of interest that is $\geq (520+78\text{ mV})$ 598 mV in intensity will be marked defective.
 - Any pixel in this region of interest that is $\leq (520-78\text{ mV})$ 442 mV in intensity will be marked defective.
- All remaining 384 sub regions of interest are analyzed for defective pixels in the same manner.

OPERATION

MAXIMUM RATINGS

Absolute maximum rating is defined as a level or condition that should not be exceeded at any time per the description. If the level or the condition is exceeded, the device will be degraded and may be damaged.

Description	Symbol	Minimum	Maximum	Units	Notes
Operating Temperature	T _{OP}	-50	70	°C	1
Humidity	RH	5	90	%	2
Output Bias Current	I _{out}	0.0	-40	mA	3
Off-chip Load	C _L		10	pF	

Notes:

- Noise performance will degrade at higher temperatures.
- T=25°C. Excessive humidity will degrade MTTF.
- Total for both outputs. Current is -20 mA for each output. Avoid shorting output pins to ground or any low impedance source during operation. Amplifier bandwidth increases at higher current and lower load capacitance at the expense of reduced gain (sensitivity). Operation at these values will reduce MTTF.

MAXIMUM VOLTAGE RATINGS BETWEEN PINS

Description	Minimum	Maximum	Units	Notes
RL, RR, H1BINL, H1BINR, H2SL, H1SL, H1BL, H2BL, H2BR, H1BR, H1SR, H2SR, OGL, OGR to ESD	0	17	V	
Pin to Pin with ESD Protection	-17	17	V	1
VDDL, VDDR to GND	0	25	V	

Notes:

- Pins with ESD protection are: RL, RR, H1BINL, H1BINR, H2SL, H1SL, H1BL, H2BL, H2BR, H1BR, H1SR, H2SR, OGL, and OGR.

DC BIAS OPERATING CONDITIONS

Description	Symbol	Minimum	Nominal	Maximum	Units	Maximum DC Current (mA)	Notes
Output Gate	OG	-3.0	-2.5	-2.0	V	1 μA	
Reset Drain	RD	10.5	11.5	12.0	V	1 μA	
Output Amplifier Supply	VDD	14.5	15.0	15.5	V	2 mA	4
Ground	GND	0.0	0.0	0.0	V		
Substrate	SUB	8.0	TBD	17.0	V		1
ESD Protection	ESD	-9.0	-8.0	-7.0	V		2
Output Bias Current	I _{out}		-5	-10	mA		3

Notes:

- The operating of the substrate voltage, V_{ab}, will be marked on the shipping container for each device. The value of V_{ab} is set such that the photodiode charge capacity is 60,000 electrons.
- VE_{SD} must be at least 1 V more negative than H1L and H2L during sensor operation *AND* during camera power turn on.
- An output load sink must be applied to V_{out} to activate output amplifier.
- The maximum DC current is for one output unloaded. This is the maximum current that the first two stages of one output amplifier will draw. This value is with V_{out} disconnected.

Power Up Sequence

- Substrate
- ESD Protection
- All other biases and clocks.

AC OPERATING CONDITIONS

Clock Levels

Description	Symbol	Minimum	Nominal	Maximum	Units	Notes
Vertical CCD Clock High	V2H	7.5	8.0	8.5	V	
Vertical CCD Clocks Midlevel	V1M, V2M	-0.2	0.0	0.2	V	
Vertical CCD Clocks Low	V1L, V2L	-9.5	-9.0	-8.5	V	
Horizontal CCD Clocks Amplitude	H1H, H2H	5.8	6.0	6.2	V	
Horizontal CCD Clocks Low	H1L, H2L	-4.2	-4.0	-3.8	V	
Reset Clock High	RH	1.3	1.5	1.7	V	
Reset Clock Low	RL	-3.7	-3.5	-3.3	V	
Electronic Shutter Voltage	Vshutter	39	40	48	V	
Fast Dump High	FDH	4.5	5.0	5.5	V	
Fast Dump Low	FDL	-9.5	-9.0	-8.5	V	1

Notes:

1. FDL can use the same supply as Vertical CCD Clocks Low if desired.

Clock Line Capacitances

Clocks	Capacitance	Units	Notes
V1 to GND	108	nF	1
V2 to GND	118	nF	1
V1 to V2	56	nF	
H1S to GND	27	pF	2
H2S to GND	27	pF	2
H1B to GND	13	pF	2
H2B to GND	4	pF	2
H1S to H2B and H2S	13	pF	2
H1B to H2B and H2S	13	pF	2
H2S to H1B and H1S	13	pF	2
H2B to H1B and H1S	13	pF	2
H1BIN to GND	20	pF	2
R to GND	10	pF	
FD to GND	20	pF	

Notes:

1. Gate capacitance to GND is voltage dependent. Value is for nominal VCCD clock voltages.
2. For nominal HCCD clock voltages, these values are for half of the imager (H1SL, H1BL, H2SL, H2BL and H1BINL or H1SR, H1BR, H2SR, H2BR and H1BINR).

TIMING REQUIREMENTS

Description	Symbol	Minimum	Nominal	Maximum	Units	Notes
HCCD Delay	T_{HD}	3.0	3.5	10.0	μ s	
VCCD Transfer time	T_{VCCD}	3.0	3.5	20.0	μ s	
Photodiode Transfer time	T_{V3rd}	8.0	10.0	15.0	μ s	
VCCD Pedestal time	T_{3P}	100.0	120.0	200.0	μ s	
VCCD Delay	T_{3D}	15.0	20.0	80.0	μ s	
Reset Pulse time	T_R	2.5	5.0		ns	
Shutter Pulse time	T_S	3.0	4.0	10.0	μ s	
Shutter Pulse delay	T_{SD}	1.0	1.5	10.0	μ s	
HCCD Clock Period	T_H	33		200	ns	
VCCD rise/fall time	T_{VR}	0.0	0.1	1.0	μ s	
Fast Dump Gate delay	T_{FD}	0.5			μ s	
Vertical Clock Edge Alignment	T_{VE}	0.0		100	ns	

Notes:

MAIN TIMING – CONTINUOUS MODE

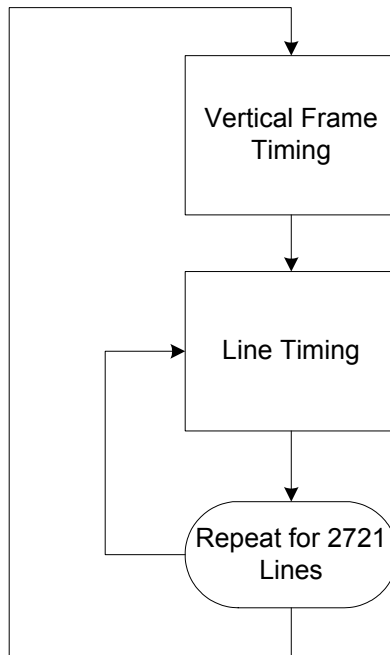

Figure 17: Main Timing - Continuous Mode

FRAME TIMING – CONTINUOUS MODE

Frame Timing without Binning

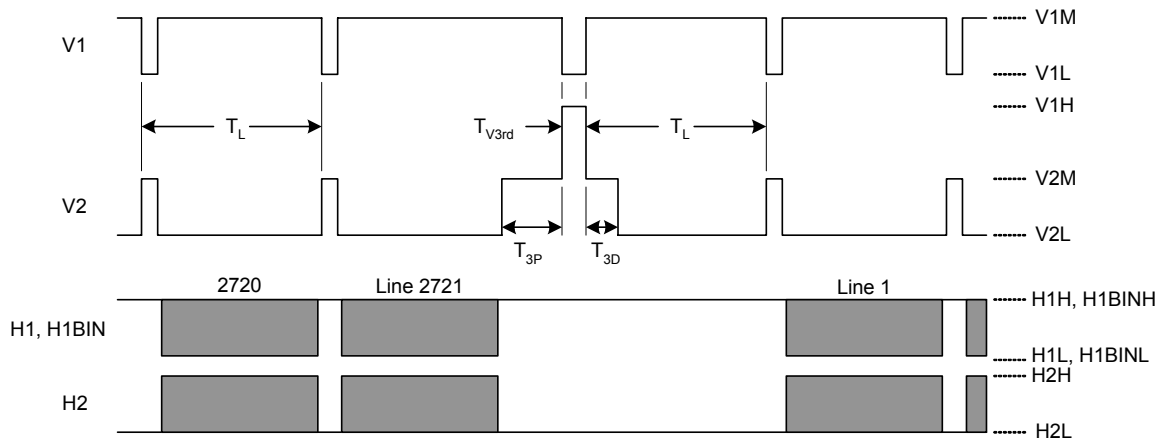

Figure 18: Framing Timing without Binning

Frame Timing for Vertical Binning by 2

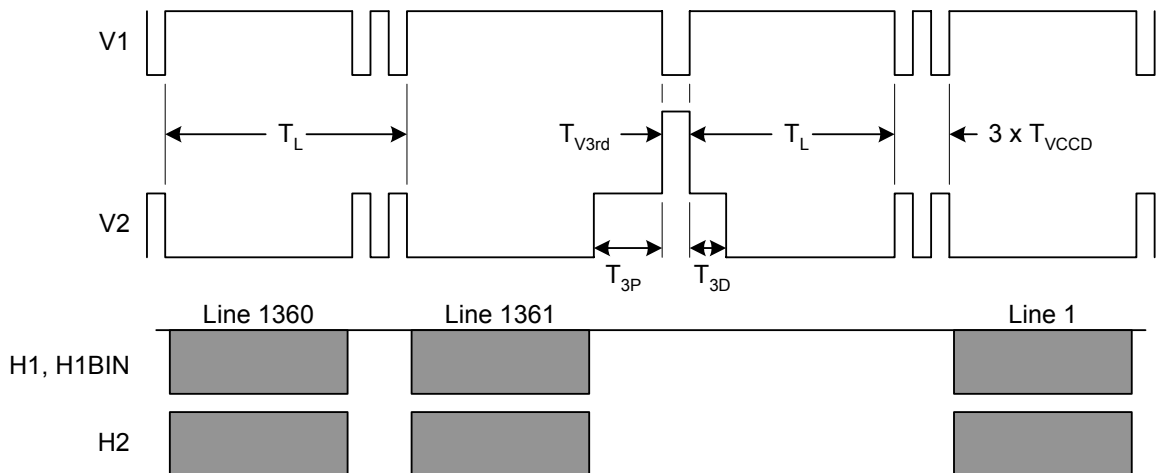

Figure 19: Frame Timing for Vertical Binning by 2

Frame Timing Edge Alignment

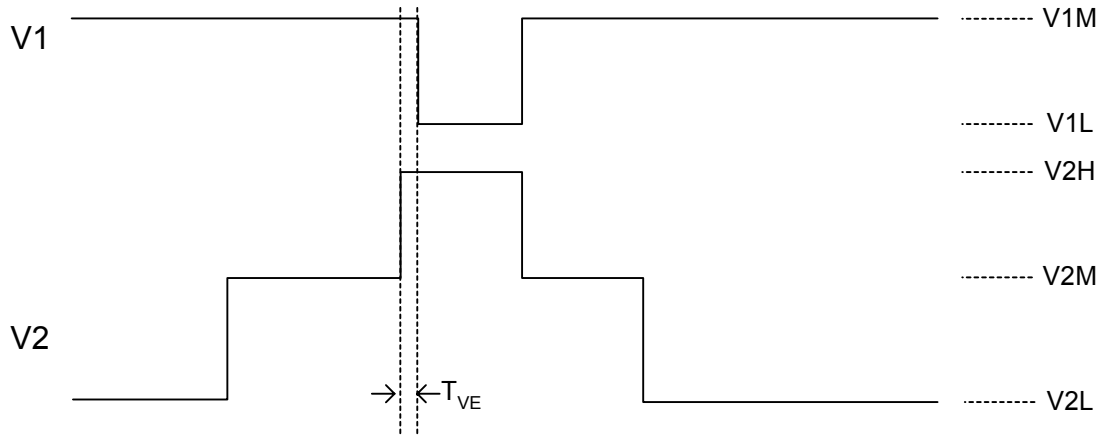

Figure 20: Frame Timing Edge Alignment

LINE TIMING – CONTINUOUS MODE

Line Timing Single Output

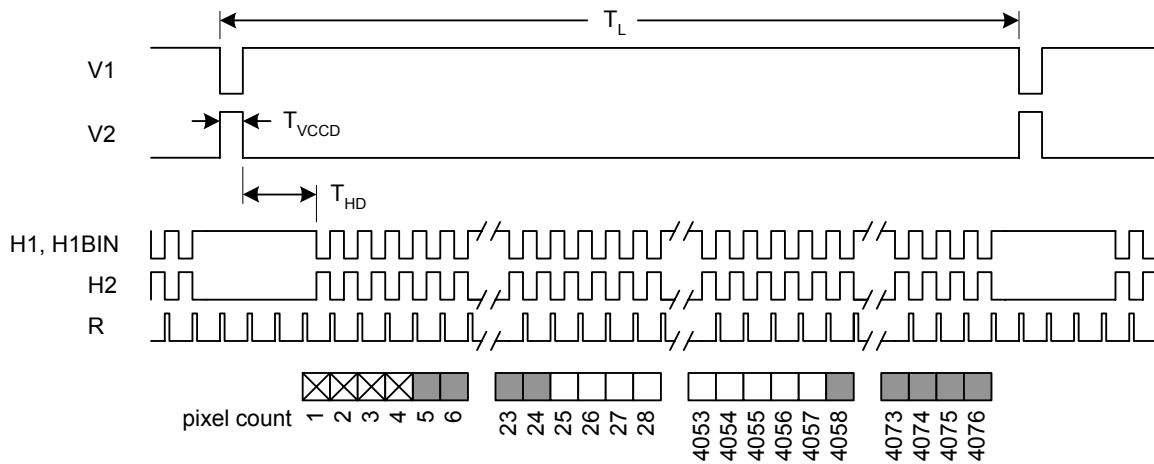

Figure 21: Line Timing Single Output

Line Timing Dual Output – Left Output

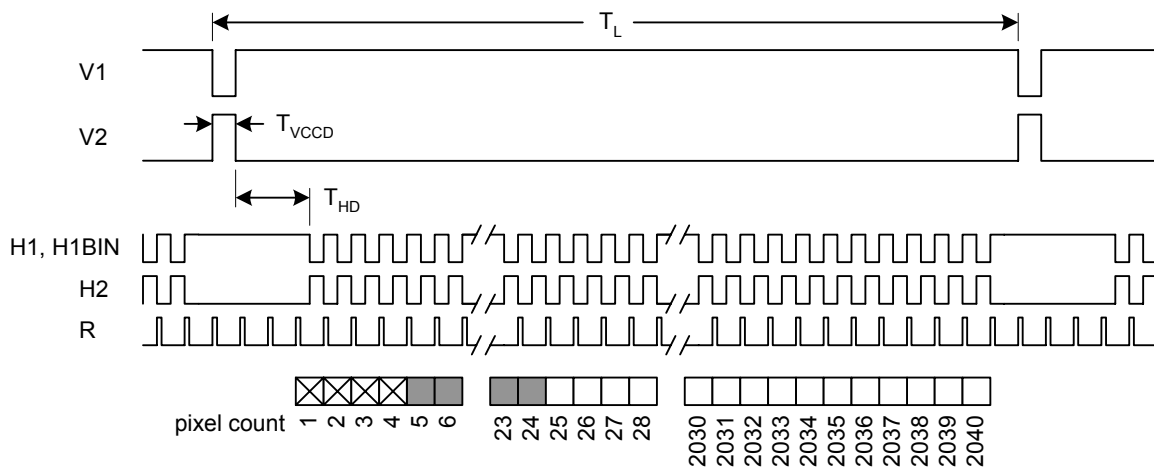

Figure 22: Line Timing Dual Output – Left Output

Line Timing Dual Output – Right Output

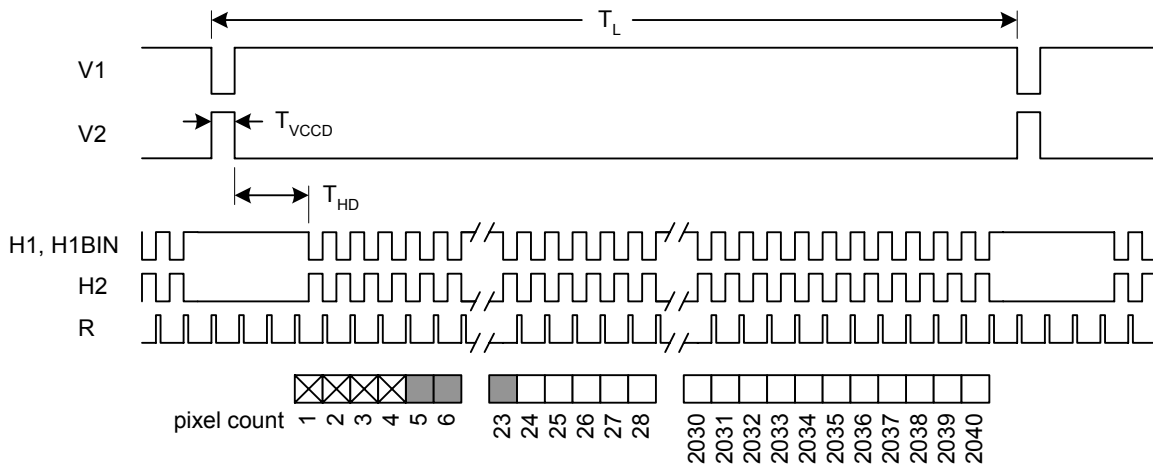

Figure 23: Line Timing Dual Output – Right Output

Line Timing Vertical Binning by 2

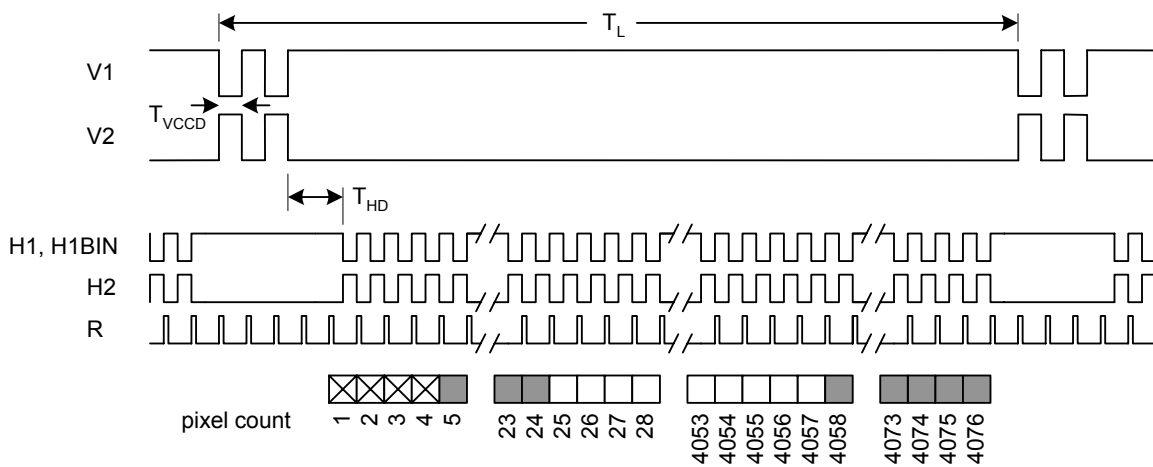

Figure 24: Line Timing Vertical Binning by 2

Line Timing Detail

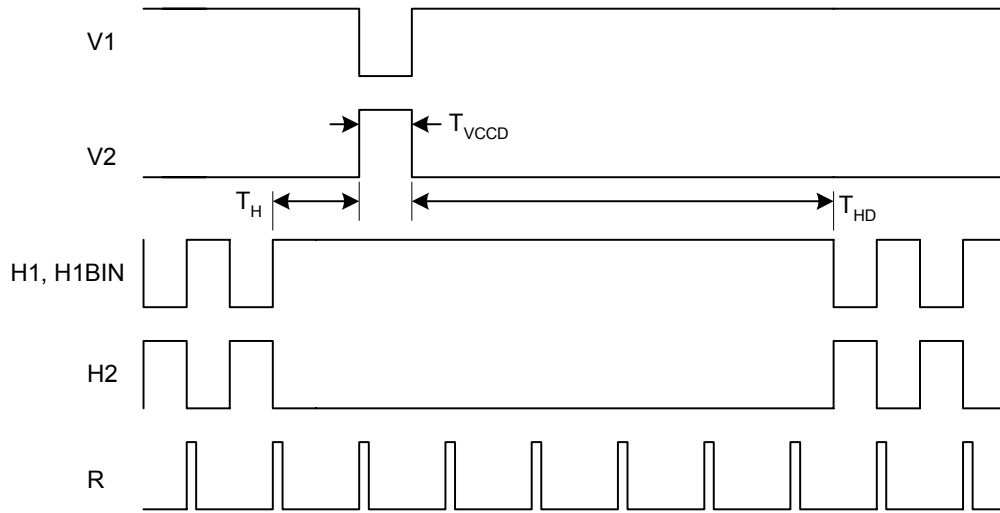

Figure 25: Line Timing Detail

Line Timing Binning by 2 Detail

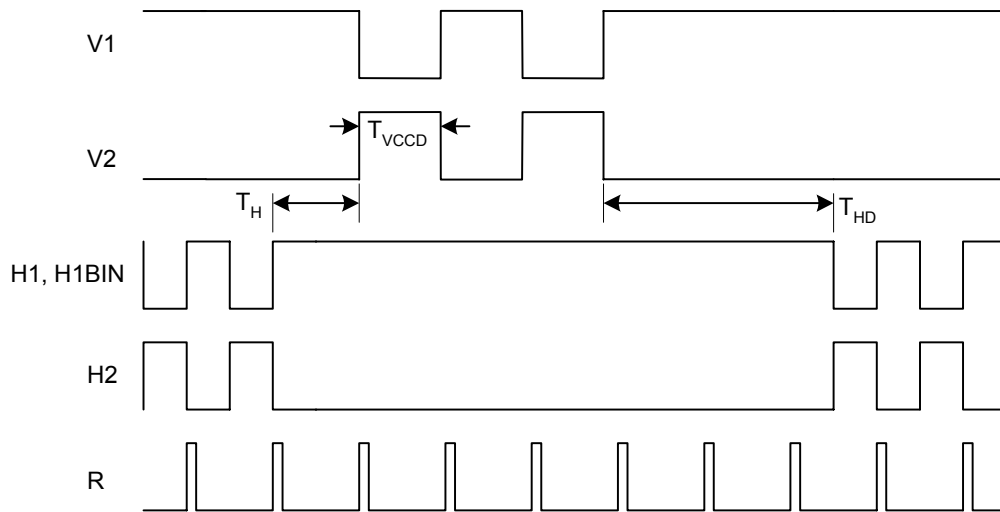

Figure 26: Line Timing by 2 Detail

Line Timing Edge Alignment

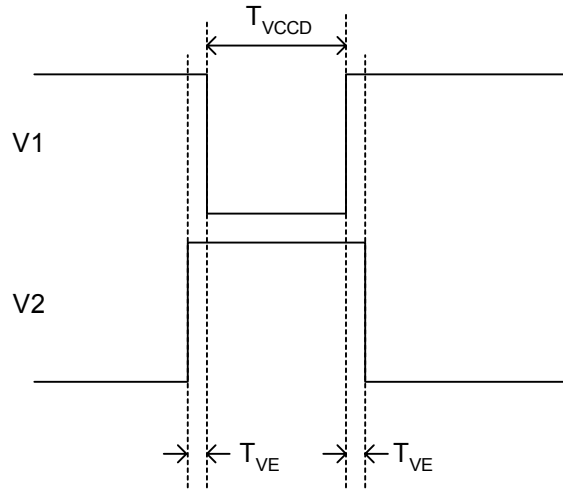

Figure 27: Line Timing Edge Alignment

PIXEL TIMING – CONTINUOUS MODE

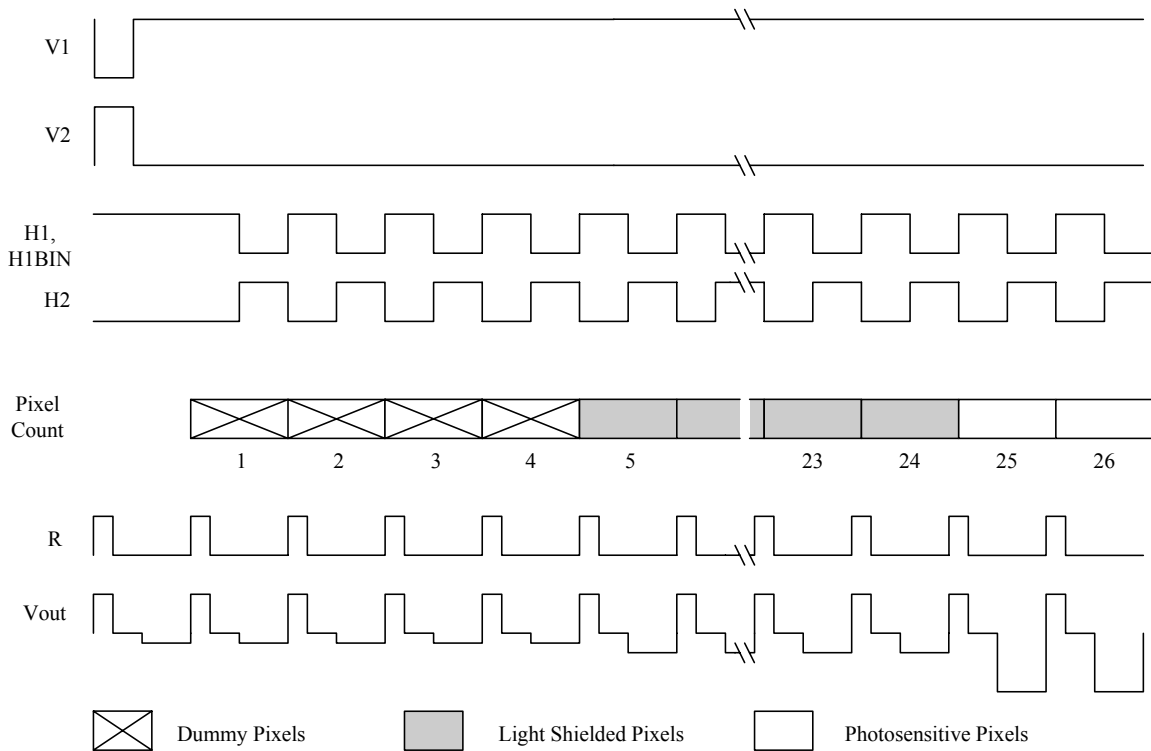

Figure 28: Pixel Timing

Pixel Timing Detail

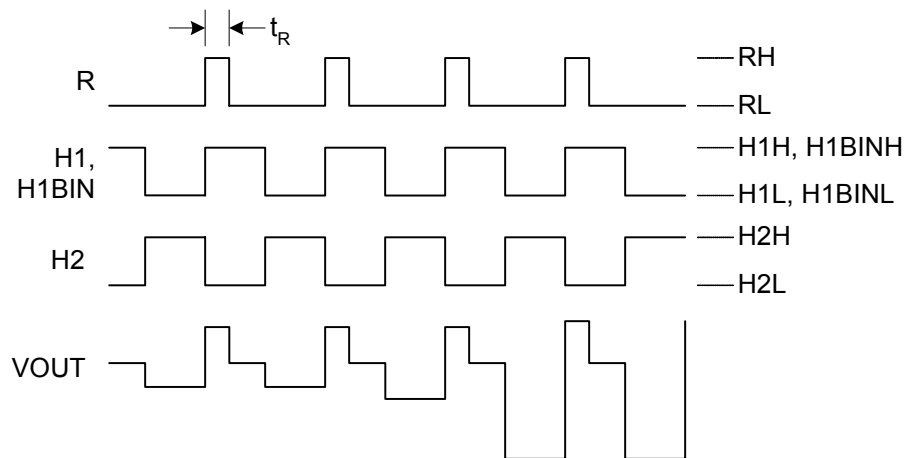

Figure 29: Pixel Timing Detail

FAST LINE DUMP TIMING

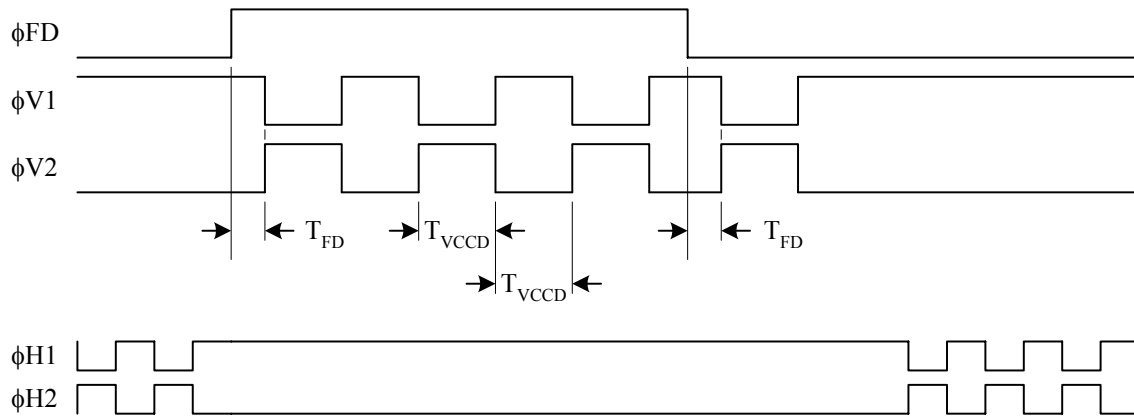

Figure 30: Fast Line Dump Timing

ELECTRONIC SHUTTER

Electronic Shutter Line Timing

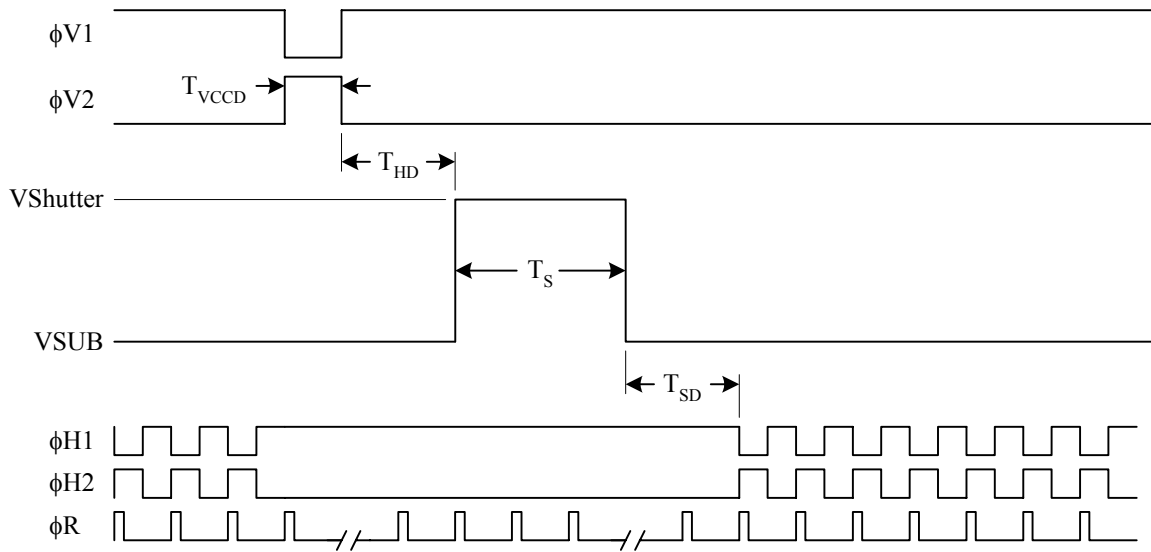

Figure 31: Electronic Shutter Line Timing

Electronic Shutter – Integration Time Definition

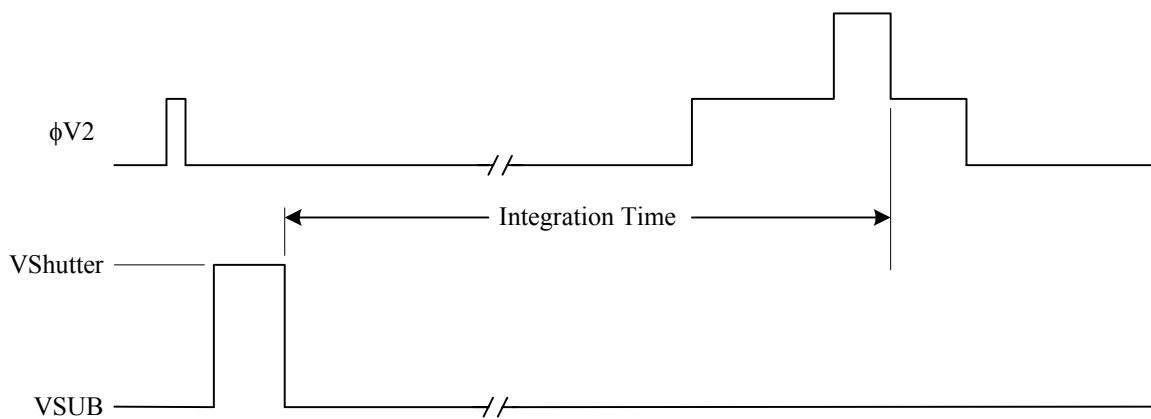

Figure 32: Integration Time Definition

Electronic Shutter Description

The voltage on the substrate (SUB) determines the charge capacity of the photodiodes. When SUB is 8 volts the photodiodes will be at their maximum charge capacity. Increasing VSUB above 8 volts decreases the charge capacity of the photodiodes until 40 volts when the photodiodes have a charge capacity of zero electrons. Therefore, a short pulse on SUB, with a peak amplitude greater than 40 volts, empties all photodiodes and provides the electronic shuttering action.

It may appear the optimal substrate voltage setting is 8 volts to obtain the maximum charge capacity and dynamic range. While setting VSUB to 8 volts will provide the maximum dynamic range, it will also provide the minimum antiblooming protection.

The KAI-11002 VCCD has a charge capacity of 90,000 electrons (90 ke^-). If the SUB voltage is set such that the photodiode holds more than 90 ke^- , then when the charge is transferred from a full photodiode to VCCD, the VCCD will overflow. This overflow condition manifests itself in the image by making bright spots appear elongated in the vertical direction. The size increase of a bright spot is called blooming when the spot doubles in size.

The blooming can be eliminated by increasing the voltage on SUB to lower the charge capacity of the photodiode. This ensures the VCCD charge capacity is greater than the photodiode capacity. There are cases where an extremely bright spot will still cause blooming in the VCCD. Normally, when the photodiode is full, any additional electrons generated by photons will spill out of the photodiode. The excess electrons are drained

harmlessly out to the substrate. There is a maximum rate at which the electrons can be drained to the substrate. If that maximum rate is exceeded, (for example, by a very bright light source) then it is possible for the total amount of charge in the photodiode to exceed the VCCD capacity. This results in blooming.

The amount of antiblooming protection also decreases when the integration time is decreased. There is a compromise between photodiode dynamic range (controlled by VSUB) and the amount of antiblooming protection. A low VSUB voltage provides the maximum dynamic range and minimum (or no) antiblooming protection. A high VSUB voltage provides lower dynamic range and maximum antiblooming protection. The optimal setting of VSUB is written on the container in which each KAI-11002 is shipped. The given VSUB voltage for each sensor is selected to provide antiblooming protection for bright spots at least 100 times saturation, while maintaining at least 60 ke^- of dynamic range.

The electronic shutter provides a method of precisely controlling the image exposure time without any mechanical components. If an integration time of T_{INT} is desired, then the substrate voltage of the sensor is pulsed to at least 40 volts T_{INT} seconds before the photodiode to VCCD transfer pulse on V2. Use of the electronic shutter does not have to wait until the previously acquired image has been completely read out of the VCCD.

STORAGE AND HANDLING

Storage Conditions

Description	Symbol	Minimum	Maximum	Units	Notes
Storage Temperature	T _{st}	-20	80	°C	1
Humidity	RH	5	90	%	2

Notes:

1. Long-term exposure toward the maximum temperature will accelerate color filter degradation.
2. T=25°C. Excessive humidity will degrade MTTF.

ESD

1. This device contains limited protection against Electrostatic Discharge (ESD). CCD image sensors can be damaged by electrostatic discharge. Failure to do so may alter device performance and reliability.
2. Devices should be handled in accordance with strict ESD procedures for Class 0 (<250V per JESD22 Human Body Model test), or Class A (<200V JESD22 Machine Model test) devices.

Devices are shipped in static-safe containers and should only be handled at static-safe workstations.

3. See Application Note MTD/PS-0224 "Electrostatic Discharge Control for Image Sensors" for proper handling and grounding procedures. This application note also contains recommendations for workplace modifications for the minimization of electrostatic discharge.
4. Store devices in containers made of electro-conductive materials.

Cover Glass Care and Cleanliness

1. The cover glass is highly susceptible to particles and other contamination. Perform all assembly operations in a clean environment.
2. Touching the cover glass must be avoided
3. Improper cleaning of the cover glass may damage these devices. Refer to Application Note MTD/PS-0237 "Cover Glass Cleaning for Image Sensors"

Environmental Exposure

1. Do not expose to strong sun light for long periods of time. The color filters and/or microlenses may become discolored. Long time exposures to a static high contrast scene should be avoided. The image sensor may become discolored and localized changes in response may occur from color filter/microlens aging.
2. Exposure to temperatures exceeding the absolute maximum levels should be avoided for storage and operation. Failure to do so may alter device performance and reliability.
3. Avoid sudden temperature changes.
4. Exposure to excessive humidity will affect device characteristics and should be avoided. Failure to do so may alter device performance and reliability.
5. Avoid storage of the product in the presence of dust or corrosive agents or gases.

Long-term storage should be avoided. Deterioration of lead solderability may occur. It is advised that the solderability of the device leads be re-inspected after an extended period of storage, over one year.

Soldering Recommendations

1. The soldering iron tip temperature is not to exceed 370°C. Failure to do so may alter device performance and reliability.
2. Flow soldering method is not recommended. Solder dipping can cause damage to the glass and harm the imaging capability of the device. Recommended method is by partial heating. Kodak recommends the use of a grounded 30W soldering iron. Heat each pin for less than 2 seconds duration.

MECHANICAL DRAWINGS

PACKAGE

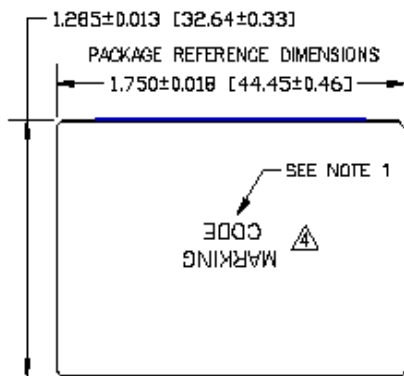
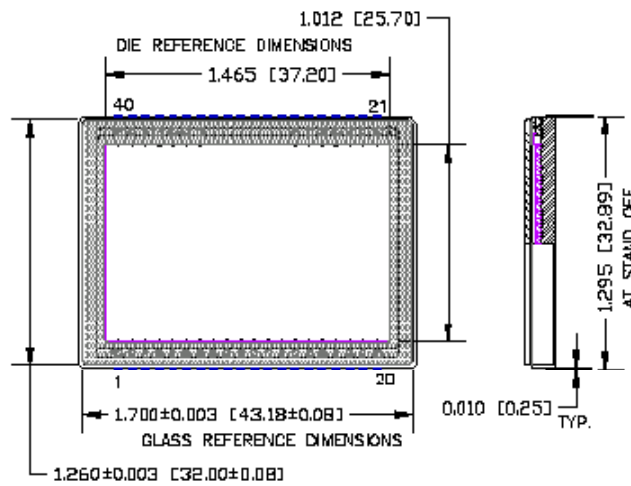

NOTES:

1. SEE ORDERING INFORMATION FOR MARKING CODE
2. COVER GLASS IS MANUALLY PLACED AND VISUALLY ALIGNED OVER DIE - LOCATION ACCURACY IS NOT GUARANTEED.

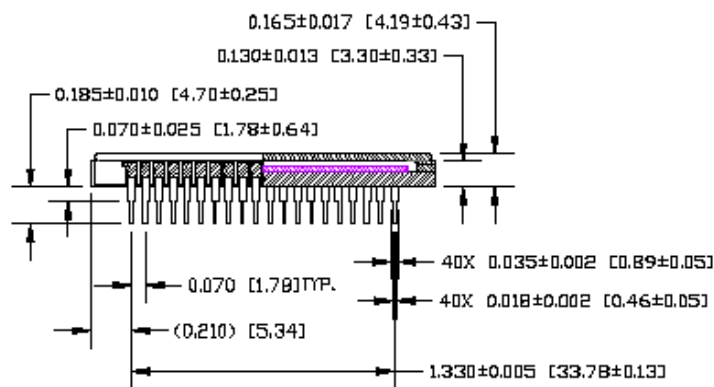
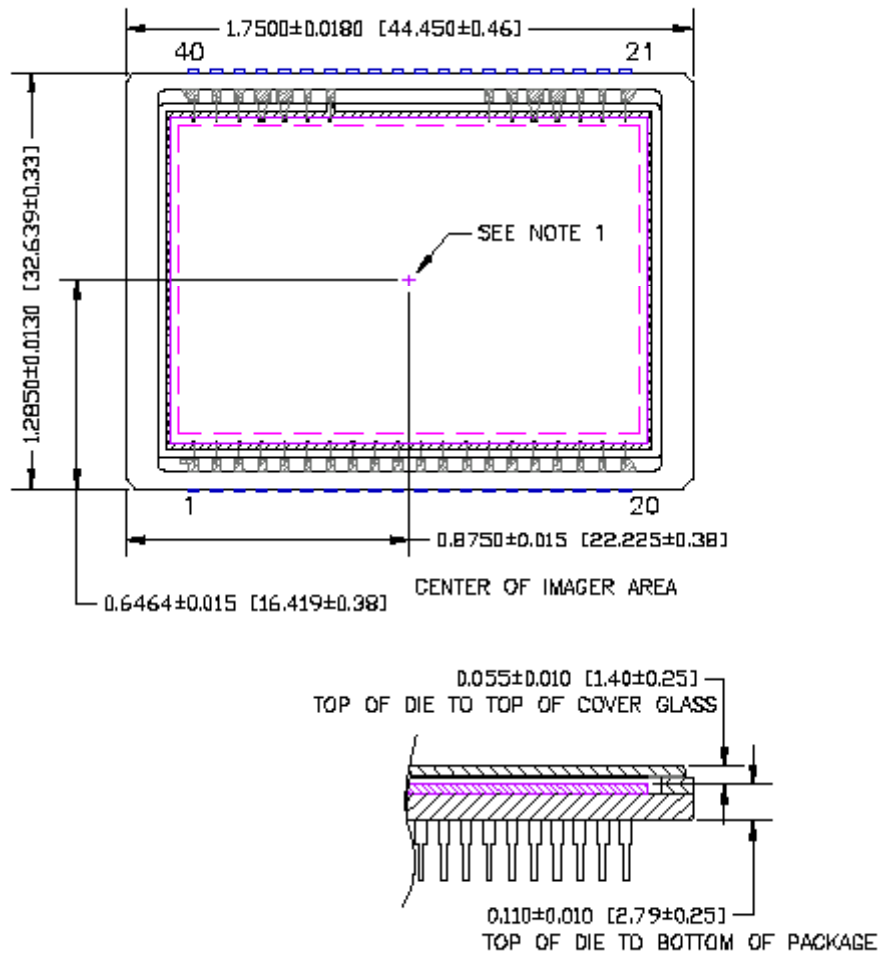

Figure 33: Package Drawing

DIE TO PACKAGE ALIGNMENT



- ⚠ NOTES:
1. CENTER OF IMAGE IS OFFSET FROM CENTER OF PACKAGE BY (0.00, 0.10)MM NOMINAL.
 2. DIE IS ALIGNED WITHIN +/- 1 DEGREES OF ANY PACKAGE CAVITY EDGE.

Figure 34: Die to Package Alignment

GLASS

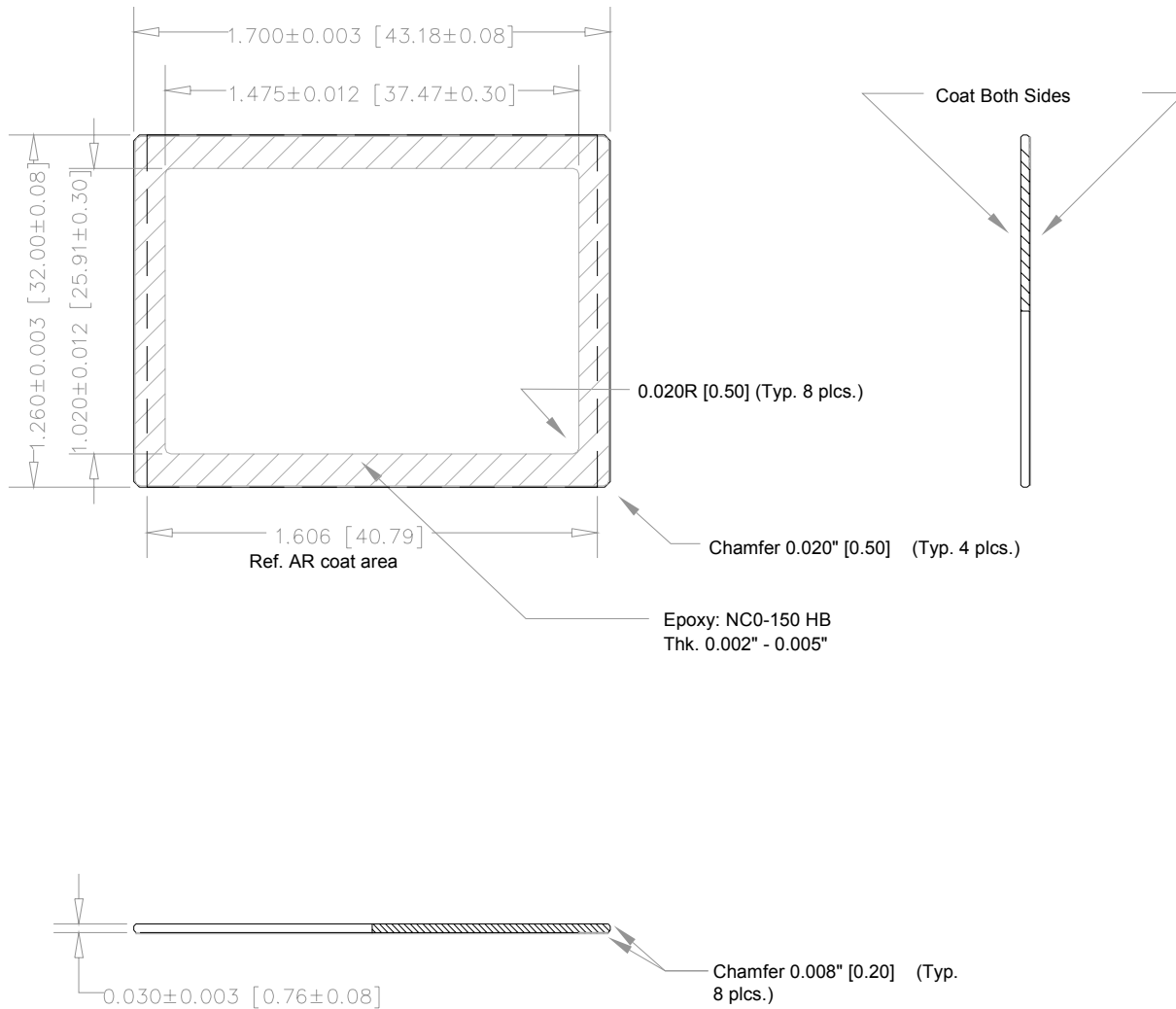

NOTES:

1. Multi-Layer Anti-Reflective Coating on 2 sides:
Double Sided Reflectance:
Range (nm)
420 - 450 nm < 2%
450 - 630 nm < 1%
630 - 680 nm < 2%
2. Dust, Scratch specification - 20 microns max.
3. Substrate - Schott D-263 or Equivalent
4. Epoxy: NCO-150HB
Thickness: 0.002" - 0.005"

Figure 35: Glass Drawing

GLASS TRANSMISSION

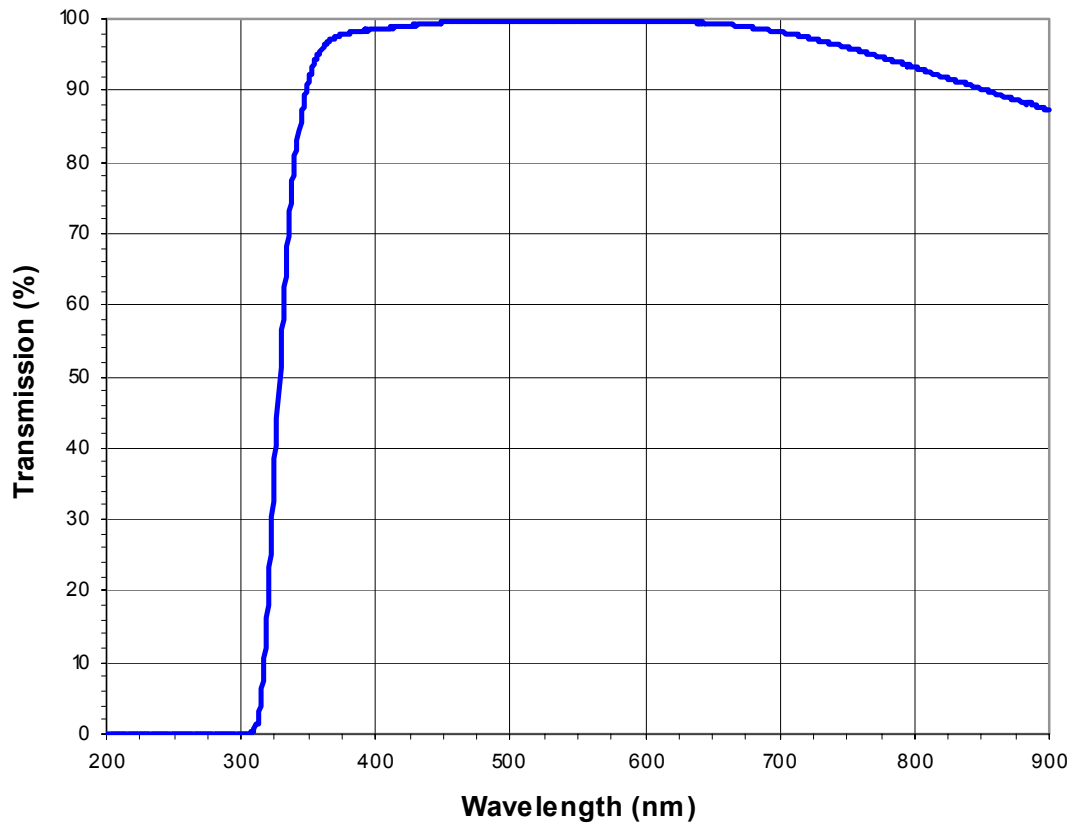

Figure 36: Glass Transmission

QUALITY ASSURANCE AND RELIABILITY

Quality Strategy: All image sensors will conform to the specifications stated in this document. This will be accomplished through a combination of statistical process control and inspection at key points of the production process. Typical specification limits are not guaranteed but provided as a design target. For further information refer to ISS Application Note MTD/PS-0292, Quality and Reliability.

Replacement: All devices are warranted against failure in accordance with the terms of Terms of Sale. This does not include failure due to mechanical and electrical causes defined as the liability of the customer below.

Liability of the Supplier: A reject is defined as an image sensor that does not meet all of the specifications in this document upon receipt by the customer.

Liability of the Customer: Damage from mechanical (scratches or breakage), electrostatic discharge (ESD) damage, or other electrical misuse of the device beyond the stated absolute maximum ratings, which occurred after receipt of the sensor by the customer, shall be the responsibility of the customer.

ESD Precautions: Devices are shipped in static-safe containers and should only be handled at static-safe workstations. See ISS Application Note MTD/PS-0224, Electrostatic Discharge Control, for handling recommendations.

Reliability: Information concerning the quality assurance and reliability testing procedures and results are available from the Image Sensor Solutions and can be supplied upon request. For further information refer to ISS Application Note MTD/PS-0292, Quality and Reliability.

Test Data Retention: Image sensors shall have an identifying number traceable to a test data file. Test data shall be kept for a period of 2 years after date of delivery.

Mechanical: The device assembly drawing is provided as a reference. The device will conform to the published package tolerances.

ORDERING INFORMATION

Available Part Configurations

Part Description	Part Marking
KAI-11002-AAA-CR-B1	KAI-11002-AAA S/N
KAI-11002-AAA-CR-B2	
KAI-11002-AAA-CR-AE	
KAI-11002-ABA-CD-BX	KAI-11002-ABA S/N
KAI-11002-ABA-CD-B0	
KAI-11002-ABA-CD-B1	
KAI-11002-ABA-CD-B2	
KAI-11002-ABA-CD-AE	

Part Description	Part Marking
KAI-11002-ABA-CR-B1	KAI-11002-ABA S/N
KAI-11002-ABA-CR-B2	
KAI-11002-ABA-CR-AE	
KAI-11002-CAA-CD-B1	KAI-11002-CAA S/N
KAI-11002-CAA-CD-B2	
KAI-11002-CAA-CD-AE	
KAI-11002-CBA-CD-B1	KAI-11002-CBA S/N
KAI-11002-CBA-CD-B2	
KAI-11002-CBA-CD-AE	

S/N – Serial Number

Class X sensors are offered strictly “as available”. Kodak cannot guarantee delivery dates. Please call for availability.

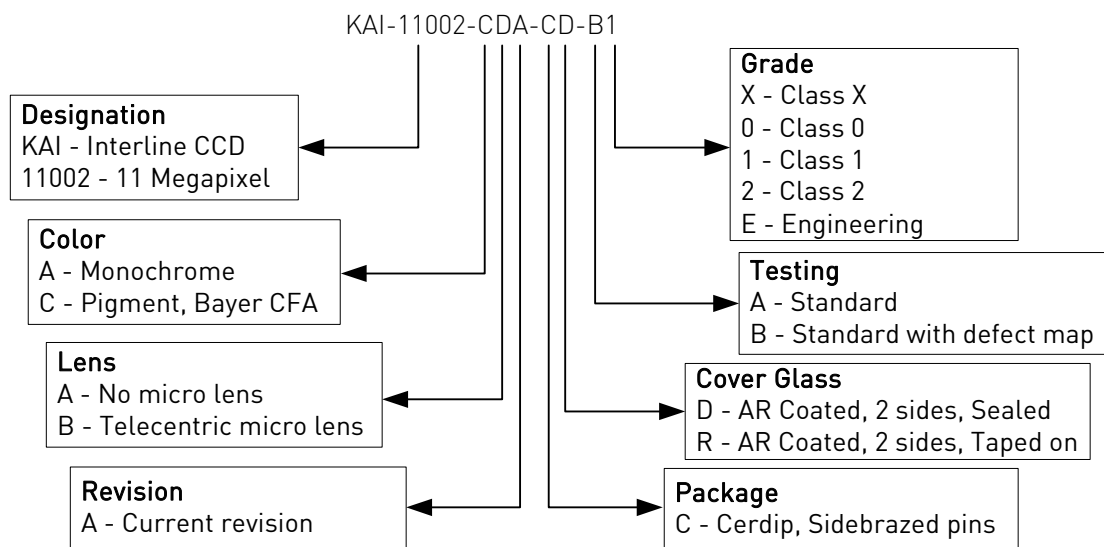

Address all inquiries and purchase orders to:

Image Sensor Solutions
Eastman Kodak Company
Rochester, New York 14650-2010
Phone: (585) 722-4385
Fax: (585) 477-4947
E-mail: imagers@kodak.com

WARNING: LIFE SUPPORT APPLICATIONS POLICY

Kodak image sensors are not authorized for and should not be used within Life Support Systems without the specific written consent of the Eastman Kodak Company. Product warranty is limited to replacement of defective components and does not cover injury or property or other consequential damages.

Kodak reserves the right to change any information contained herein without notice. All information furnished by Kodak is believed to be accurate.

REVISION CHANGES

Revision Number	Description of Changes
1.0	<ul style="list-style-type: none"><li data-bbox="310 445 554 470">• Initial formal release

This page intentionally left blank.



©Eastman Kodak Company, 2006. Kodak and Pixelux are trademarks.